

### 3. ECB (Electronically Controlled Brake System)

#### General

- In this system, the conventional brake booster portion has been discontinued. Instead, it consists of brake input, power supply, and hydraulic pressure control portions.
- During normal braking, the fluid pressure generated by the master cylinder does not directly actuate the wheel cylinders, but serves as a hydraulic pressure signal. Instead, the actual control pressure is obtained by regulating the fluid pressure of the hydraulic power source in the brake actuator, which actuates the wheel cylinders.
- The ECB (Electronically Controlled Brake System) executes the hydraulic control of the ABS with EBD, brake assist, TRAC, and VSC function in accordance with information provided by the sensors and ECUs.
- The power source backup unit is used as an auxiliary power source, to supply power to the brake system in a stable manner.

#### ► Outline of ECB (Electronically Controlled Brake System) ◀

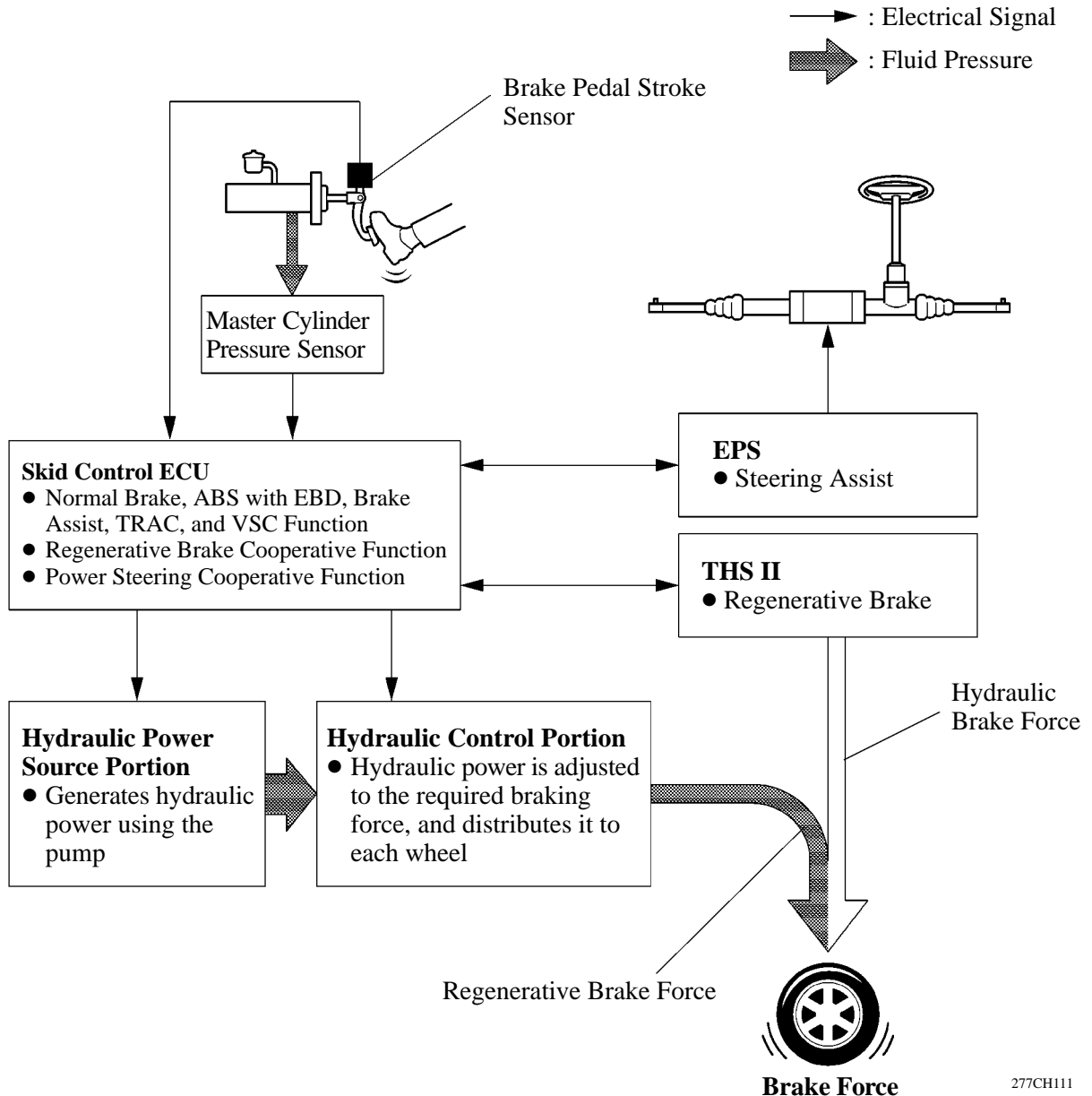

## Outline of EBD Control Function

### 1) General

The distribution of the brake force, which was performed mechanically in the past, is now performed under electrical control of the skid control ECU, which precisely controls the braking force in accordance with the vehicle's driving conditions.

### 2) Front/Rear Wheels Brake Force Distribution

If the brakes are applied while the vehicle is moving straight forward, the transfer of the road reduces the load that is applied to the rear wheels. The skid control ECU determines this condition by way of the signals from the speed sensors, and the brake actuator regulates the distribution of the brake force of the rear wheels to optimally control.

For example, the amount of the brake force that is applied to the rear wheels during braking varies whether or not the vehicle is carrying a load. The amount of the brake force that is applied to the rear wheels also varies in accordance with the extent of the deceleration.

Thus, the distribution of the brake force to the rear is optimally controlled in order to effectively utilize the braking force of the rear wheels under these conditions.

#### ► EBD Control Concept ◀

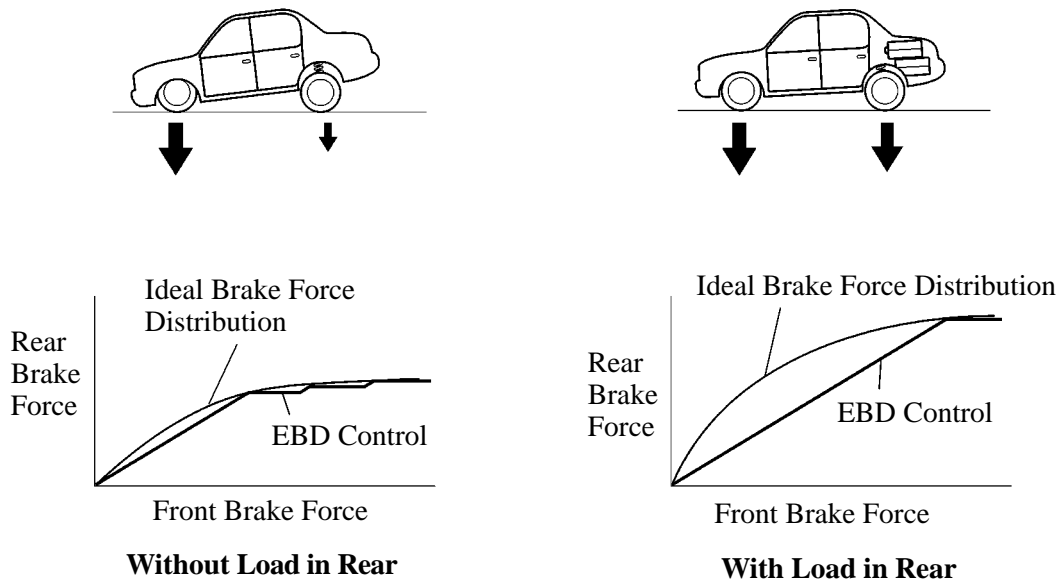

182CH56

### 3) Right/Left Wheels Brake Force Distribution (During Cornering Braking)

When the brakes are applied while the vehicle is cornering, the load that applied to the inner wheel decreases and the outer wheel increases.

The skid control ECU determines this condition by way of the signals from the speed sensors, and the brake actuator regulates the brake force in order to optimally control the distribution of the brake force to the inner wheel and outer wheel.

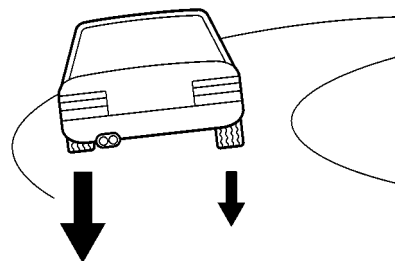

181CH56

**Outline of Brake Assist Function**

The brake assist function interprets a quick push of the brake pedal as emergency braking and supplements the braking power applied if the driver has not stepped hard enough on the brake pedal. In emergencies, drivers, especially inexperienced ones, often panic and do not apply sufficient pressure on the brake pedal. Based on the signals from the master cylinder pressure sensors and the brake pedal stroke sensor, the skid control ECU calculates the speed and the amount of the brake pedal application and then determines the intention of the driver to make an emergency braking. If the skid control ECU determines that the driver intends emergency braking, the function activates the brake actuator to increase the brake fluid pressure. The brake assist function in combination with ABS helps ensure the vehicle's brake performance. A key feature of Brake Assist function is that the timing and the degree of braking assistance are designed to ensure that the driver does not discern anything unusual about the braking operation. When the driver intentionally eases up on the brake pedal, the function reduces the amount of assistance it provides.

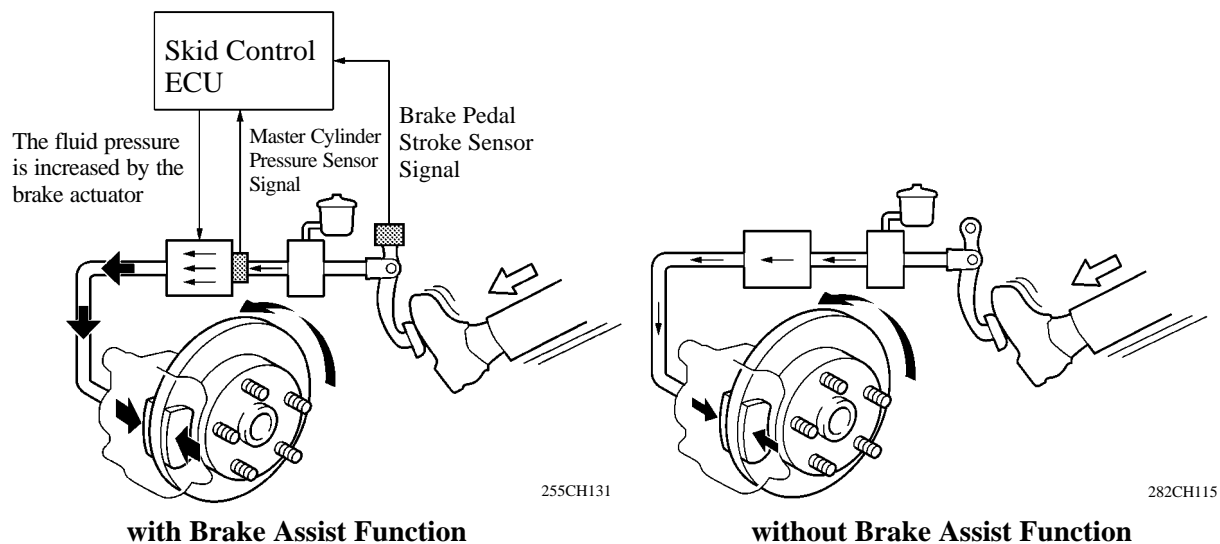

◆: There is no difference of the maximum brake performance between the vehicles with and without brake assist function.

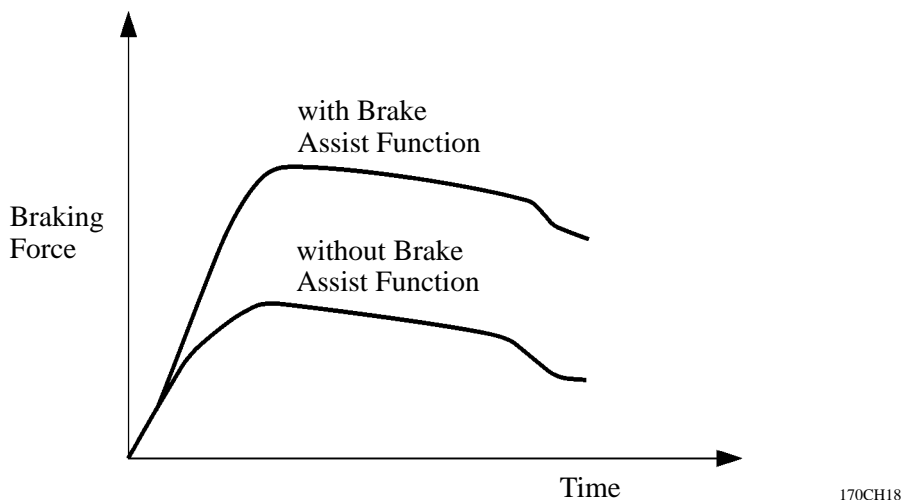

**Outline of TRAC Function**

- If the driver presses the accelerator pedal aggressively when starting off or accelerating on a slippery surface, the drive wheel could slip due to the excessive amount of torque that is generated. The adjustment of the motive force and the control of the hydraulic brakes of the drive wheels accomplished by THS II allow the TRAC function to help minimize the slippage of the drive wheels, and generate the drive force that is appropriate for the road surface conditions.
- For example, a comparison may be made between two vehicles, one with the TRAC function and the other without. If the driver of each vehicle operates the accelerator pedal in a rough manner while driving over a surface with different surface friction characteristics, the drive wheel on the slippery surface could slip as illustrated. As a result, the vehicle could become unstable. However, when the vehicle is equipped with the TRAC function, the skid control ECU instantly determines the state of the vehicle and operates the brake actuator in order to apply the brake of the slipping drive wheel. Simultaneously, the skid control ECU effects cooperative control with the THS ECU, in order to adjust the motive force. Thus, this function can constantly maintain a stable vehicle posture.

▶ **Driving condition on road with different surface friction characteristics** ◀

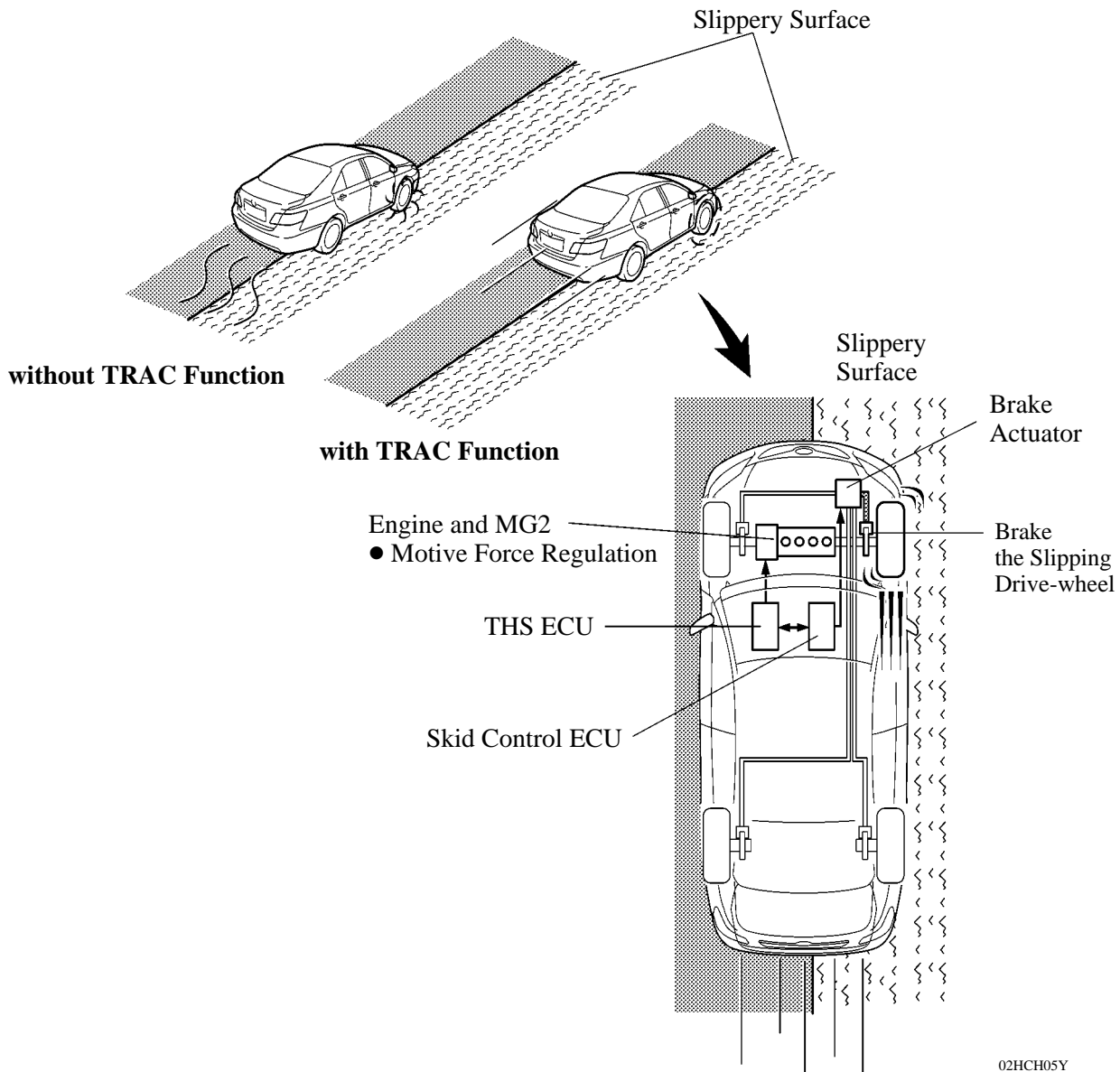

## Outline of VSC Function

### 1) General

The followings are two examples that can be considered as circumstances in which the tires exceed their lateral grip limit.

The VSC function is designed to help control the vehicle behavior by controlling the motive force and the brakes at each wheel when the vehicle is under one of the conditions indicated below.

- When the front wheels lose grip in relation to the rear wheels (front wheel skid tendency).
- When the rear wheels lose grip in relation to the front wheels (rear wheel skid tendency).

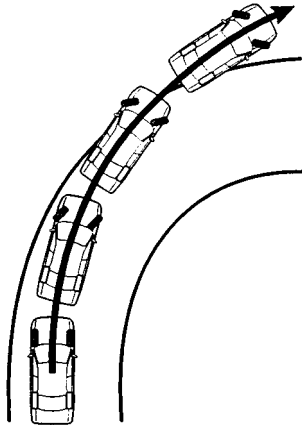

Front Wheel Skid Tendency

151CH17

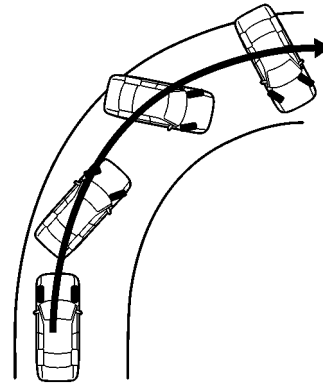

Rear Wheel Skid Tendency

189CH100

### 2) Method for Determining the Vehicle Condition

To determine the condition of the vehicle, sensors detect the steering angle, vehicle speed, vehicle's yaw rate, and the vehicle's lateral acceleration, which are then calculated by the skid control ECU.

#### a. Determining Front Wheel Skid

Whether or not the vehicle is in the state of front wheel skid is determined by the difference between the target yaw rate and the vehicle's actual yaw rate.

When the vehicle's actual yaw rate is smaller than the yaw rate (a target yaw rate that is determined by the vehicle speed and steering angle) that should be rightfully generated when the driver operates the steering wheel, it means the vehicle is making a turn at a greater angle than the locus of travel.

Thus, the skid control ECU determines that there is a large tendency to front wheel skid.

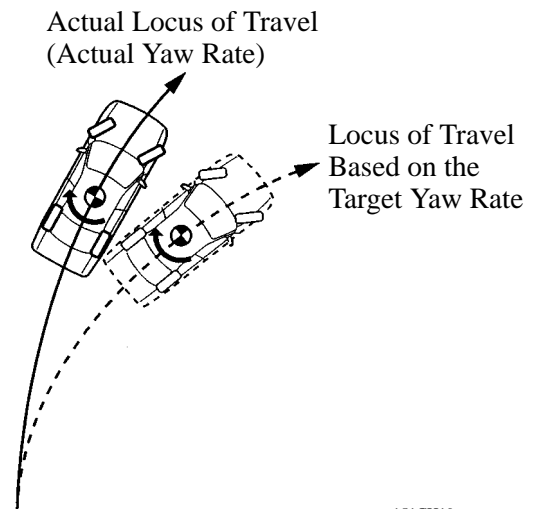

151CH19

**b. Determining Rear Wheel Skid**

Whether or not the vehicle is in the state of rear wheel skid is determined by the values of the vehicle's slip angle and the vehicle's slip angular velocity (time-dependent changes in the vehicle's slip angle). When the vehicle's slip angle is large, and the slip angular velocity is also large, the skid control ECU determines that the vehicle has a large rear wheel skid tendency.

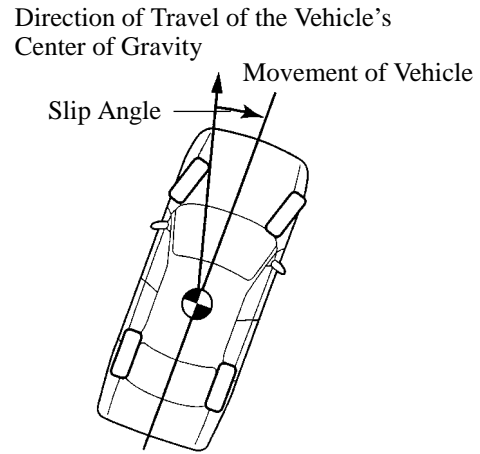

151CH18

**3) Method for VSC Operation**

When the skid control ECU determines that the vehicle exhibits a tendency to front wheel skid or rear wheel skid, it decreases the motive force and applies the brake of a front or rear wheel to control the vehicle's yaw moment.

The basic operation of the VSC is described below. However, the control method differs depending on the vehicle's characteristics and driving conditions.

**a. Dampening a Front Wheel Skid**

When the skid control ECU determines that there is a large front wheel skid tendency, it counteracts in accordance with the extent of that tendency. The skid control ECU controls the motive power output and applies the brakes of the front wheel of the outer circle in the turns and rear wheels in order to restrain the front wheel skid tendency.

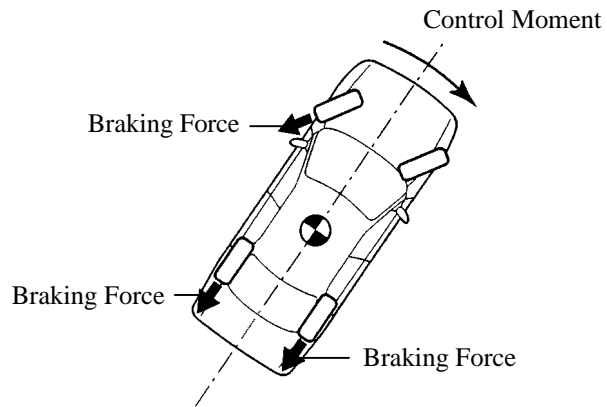

189CH101

**Making a Right Turn**

**b. Dampening a Rear Wheel Skid**

When the skid control ECU determines that there is a large rear wheel skid tendency, it counteracts in accordance with the extent of that tendency. It applies the brakes of the front wheel of the outer circle of the turn, and generates an outward moment of inertia in the vehicle, in order to restrain the rear wheel skid tendency. Along with the reduction in the vehicle speed caused by the braking force, the excellent vehicle's stability is ensured.

In some cases, the skid control ECU applies the brake of the rear wheels, as necessary.

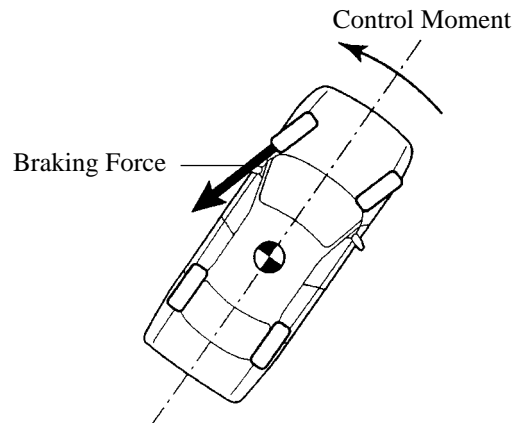

204CH15

**Making a Right Turn**

System Diagram

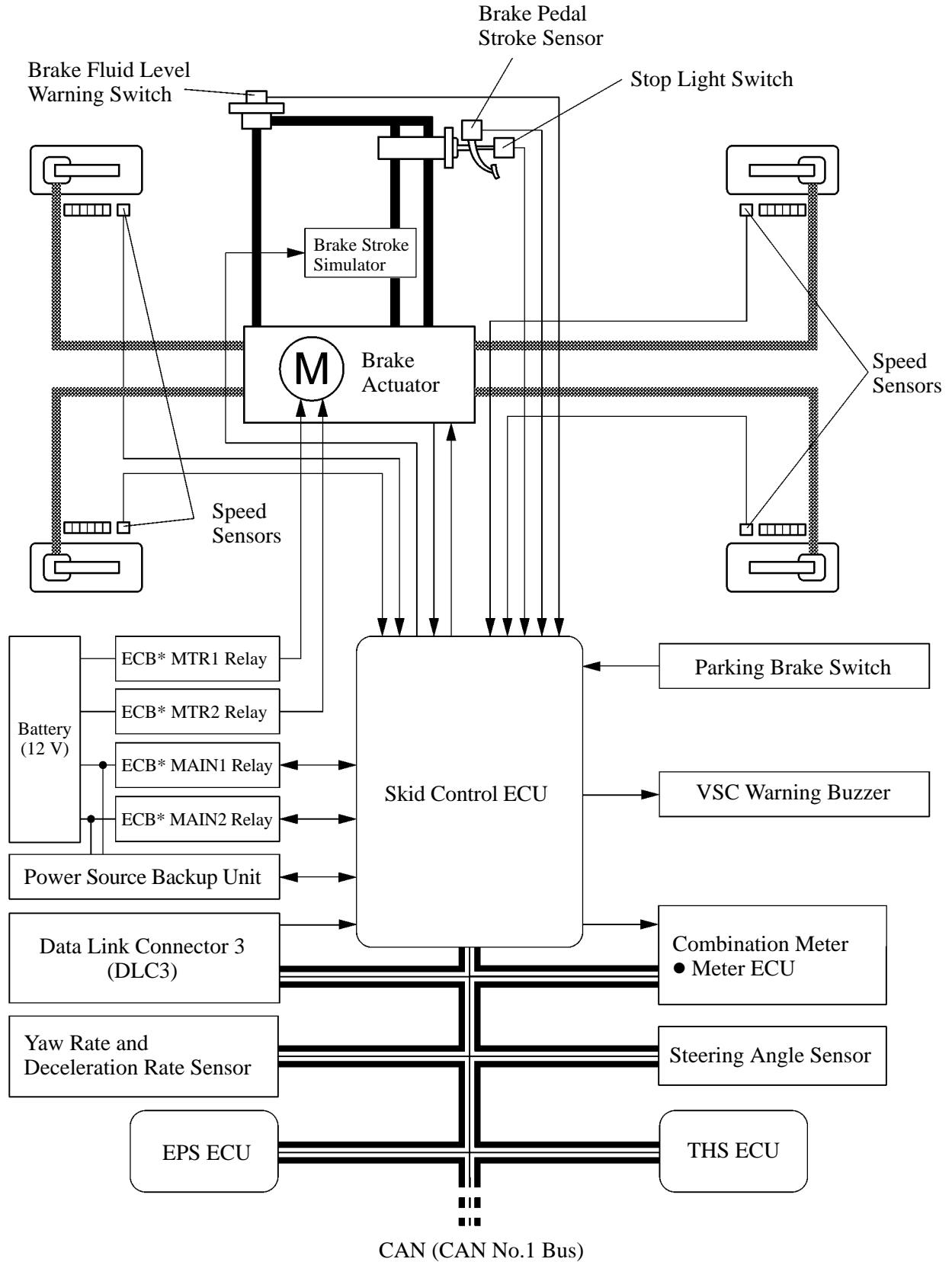

\*: ECB (Electronically Controlled Brake System)

**Construction**

The configuration of the brake control system is as shown in the following chart.

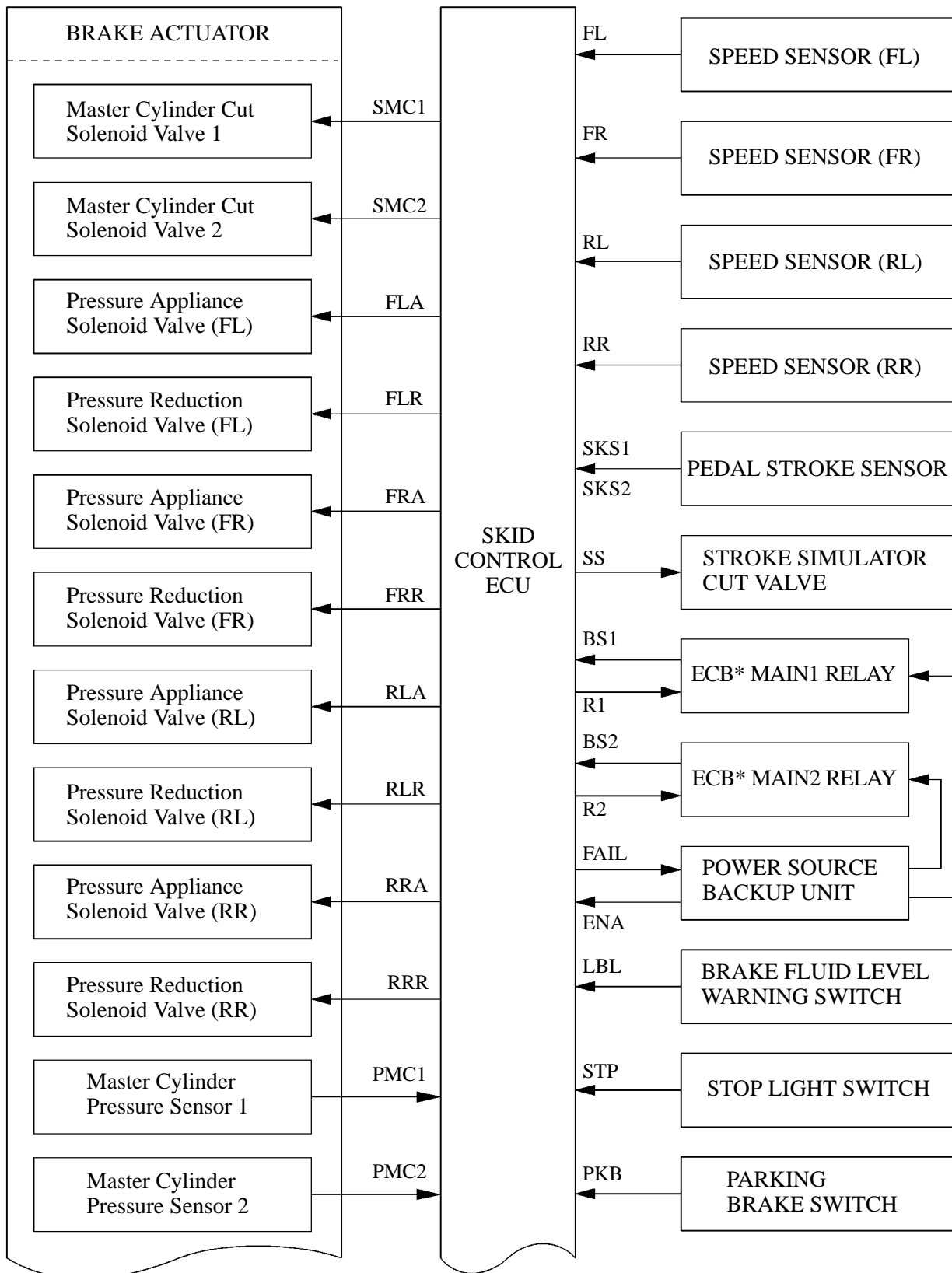

(Continued)

\*: ECB (Electronically Controlled Brake System)



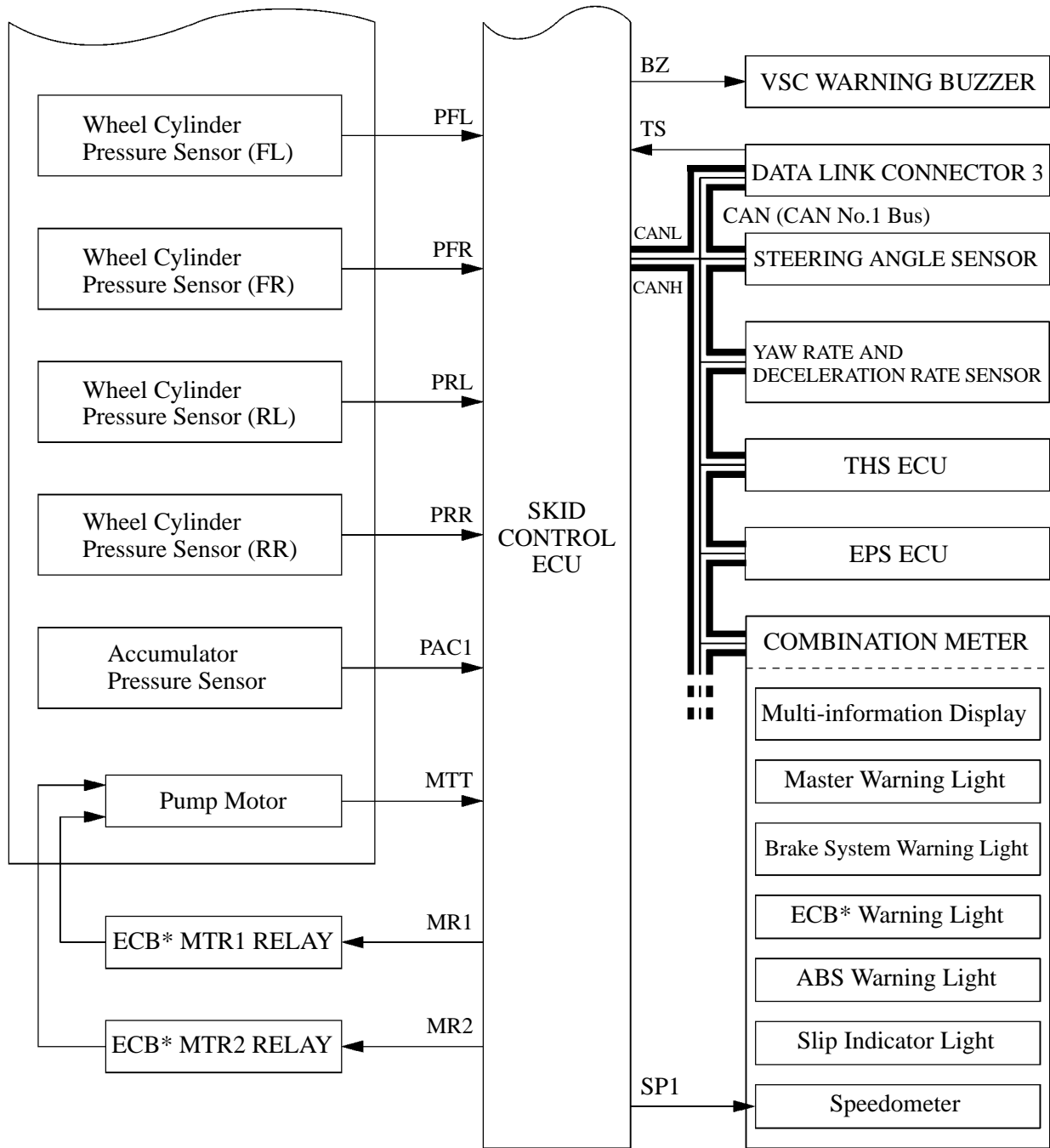

\*: ECB (Electronically Controlled Brake System)

Layout of Main Components

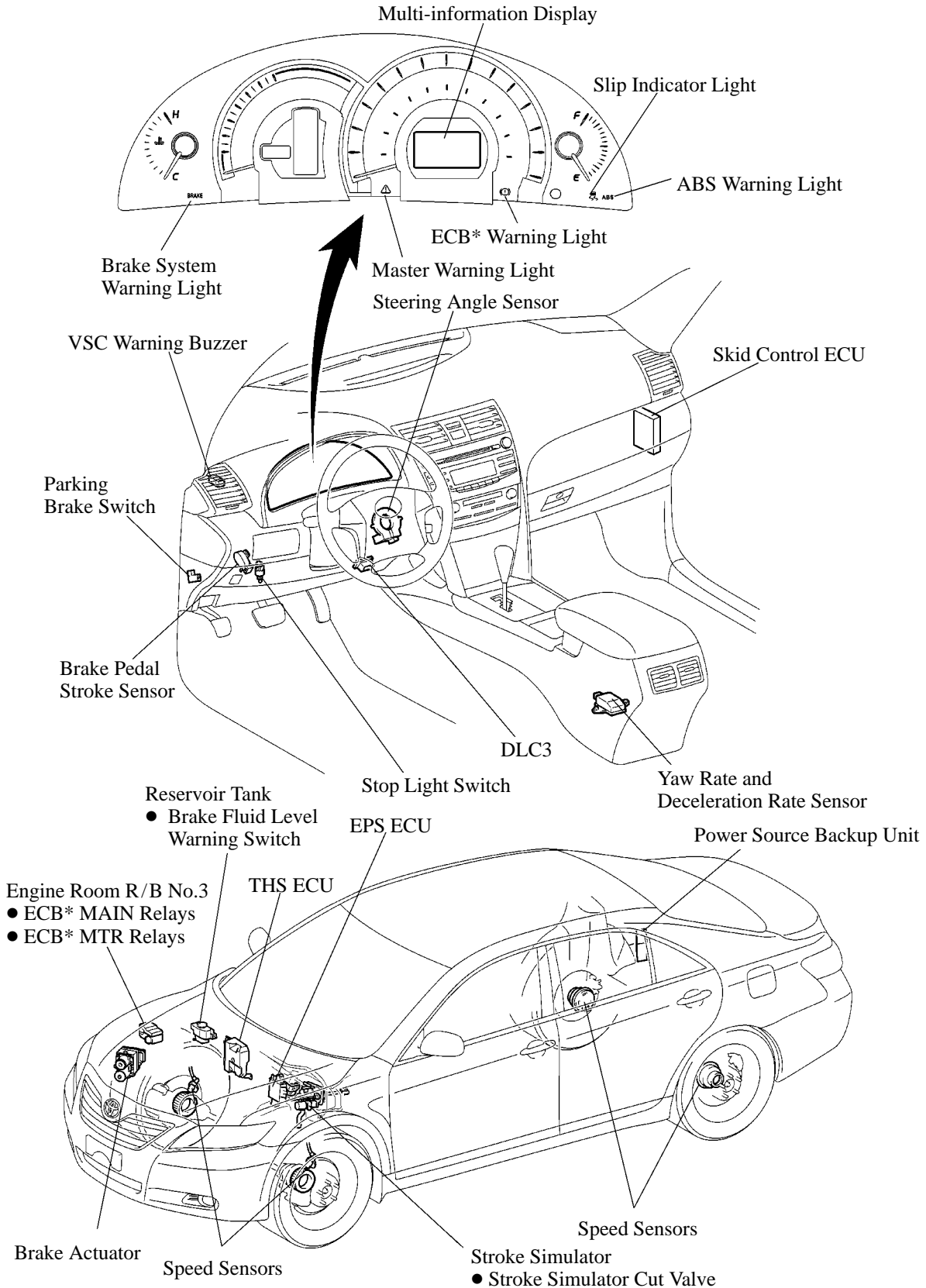

02HCH12TE

\*: ECB (Electronically Controlled Brake System)

## Function of Main Components

Component		Function
Brake Actuator (See Page CH-45)	Hydraulic Power Source Portion	<ul style="list-style-type: none"> <li>Consists of a pump, pump motor, accumulator, and relief valve, and generates and stores the hydraulic pressure, which the skid control ECU uses for controlling braking.</li> <li>The accumulator pressure sensor is installed in the brake actuator.</li> </ul>
	Hydraulic Control Portion	<ul style="list-style-type: none"> <li>Consists of 2 master cylinder cut solenoid valves, 4 pressure appliance solenoid valves, and 4 pressure reduction solenoid valves.</li> <li>The 2 master cylinder cut solenoid valves, which are the two-position type, are controlled by the skid control ECU to open and close the passage between the master cylinder and the wheel cylinders.</li> <li>The 4 pressure appliance solenoid valves and the 4 pressure reduction solenoid valves are the linear type. They are controlled by the skid control ECU to increase and decrease the fluid pressure in the wheel cylinders.</li> <li>The master cylinder pressure sensors and the wheel cylinder pressure sensors are installed in the brake actuator.</li> </ul>
Skid Control ECU		Monitors the driving conditions of the vehicle in accordance with the signals received from the sensors and through cooperative control with the THS ECU and EPS ECU, calculates the required amount of braking force, and controls the brake actuator.
Brake Master Cylinder		<ul style="list-style-type: none"> <li>Generates hydraulic pressure in accordance with the amount of effort applied to the brake pedal by the driver.</li> <li>When a malfunction occurs in the power supply portion, the brake master cylinder supplies the fluid pressure (which is generated by the brake pedal effort) directly to the wheel cylinders.</li> </ul>
Brake Pedal Stroke Sensor (See Page CH-50)		Directly detects the extent of the brake pedal stroke operated by the driver.
Stroke Simulator (See Page CH-51)		Generates a pedal stroke during braking in accordance with the driver's pedal effort.
	Stroke Simulator Cut Valve	Allows the fluid pressure generated by the master cylinder to flow into the stroke simulator while the ECB* operates.
Combination Meter	Multi-information Display and Master Warning Light	Informs the driver of a failure in the VSC function by displaying a message on the multi-information display in the combination meter and blinking the master warning light.
	ABS Warning Light	Lights up to alert the driver that the skid control ECU detects the malfunction in the ABS, EBD, or Brake Assist function.
	Slip Indicator Light	Blinks to inform the driver that the ABS function, the VSC function or the TRAC function is operated.
	ECB* Warning Light	Lights up to alert the driver that a minor malfunction occurs in the brake system, which does not affect the braking force (such as a malfunction in the regenerative brake).
	Brake System Warning Light	<ul style="list-style-type: none"> <li>Lights up to alert the driver that the skid control ECU detects the malfunction in the apportioning of the brake.</li> <li>Lights up to inform the driver that the parking brake is ON or the brake fluid level is low.</li> </ul>

\*: ECB (Electronically Controlled Brake System)

(Continued)

Component	Function
VSC Warning Buzzer	<ul style="list-style-type: none"> <li>● Sounds continuously to inform the driver that there is a malfunction in the hydraulic pressure or a failure in the power supply.</li> <li>● Sounds intermittently to inform the driver of the vehicle skidding.</li> </ul>
THS ECU	<ul style="list-style-type: none"> <li>● Actuates the regenerative brake on receiving a signal from the skid control ECU.</li> <li>● Sends the actual regenerative brake control value to the skid control ECU.</li> <li>● Controls the motive force based on an output control request signal received from the skid control ECU while the VSC function or TRAC function is operating.</li> </ul>
Reservoir Tank	Stores the brake fluid.
Brake Fluid Level Warning Switch	Detects the low brake fluid level.
Stop Light Switch	Detects the brake pedal-depressing signal.
Yaw Rate and Deceleration Rate Sensor (See Page CH-51)	<ul style="list-style-type: none"> <li>● Detects the vehicle's yaw rate.</li> <li>● Detects the vehicle's acceleration in the forward, rearward, and lateral.</li> </ul>
Steering Angle Sensor (See Page CH-52)	Detects the steering direction and angle of the steering wheel.
Speed Sensor	Detects the wheel speed of each of 4 wheels.
ECB* MTR Relays	<ul style="list-style-type: none"> <li>● Two types of pump motor relays with different pump actuation speeds.</li> <li>● If one relay fails, the other relay operates to actuate the pump.</li> </ul>
ECB* MAIN Relays	Controlled by the skid control ECU, and supply or stop power to the solenoid valves in the brake actuator and the skid control ECU.
Power Source Backup Unit (See Page CH-52)	<ul style="list-style-type: none"> <li>● An auxiliary power supply to provide stable power to the brake system.</li> <li>● Complements the supply of power to the brake system by discharging the electric charge that is stored in the unit when the voltage of the (12 V) power supply of the vehicle is low.</li> </ul>

\*: ECB (Electronically Controlled Brake System)

## Construction and Operation of Main Components

### 1) Brake Actuator

#### a. General

- The brake actuator consists of hydraulic control and hydraulic power source portions.
- The two master cylinder pressure sensors, four wheel cylinder pressure sensors, and an accumulator pressure sensor are installed in the brake actuator.

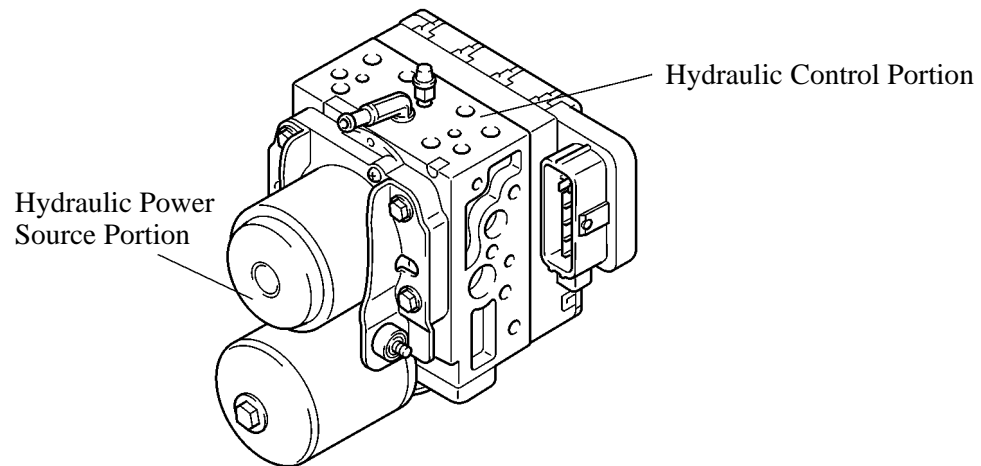

02HCH13Y

### ► Function of Main Components ◀

Component	Function
Master Cylinder Cut Solenoid Valve (2-position Type)	<ul style="list-style-type: none"> <li>• When the brake system is started, this valve cuts the hydraulic passage between the master cylinder and the wheel cylinder.</li> <li>• When the brake system is stopped or a failure occurs in the hydraulic power source portion, the valve opens to maintain the hydraulic passage to the front wheel cylinders and ensure braking. However, a greater effort than normal is required to press the brake pedal.</li> </ul>
Pressure Appliance Solenoid Valve (Linear Type)	This valve, which is controlled by the skid control ECU, regulates the fluid pressure from the accumulator in order to amplify the fluid pressure to the wheel cylinder.
Pressure Reduction Solenoid Valve (Linear Type)	This valve, which is controlled by the skid control ECU, regulates the fluid pressure in order to reduce the fluid pressure to the wheel cylinder.
Master Cylinder Pressure Sensors	The master cylinder pressure sensor converts the fluid pressure generated by the master cylinder into electrical signals and transmits them to the skid control ECU. Accordingly, the skid control ECU determines the braking force required by the driver.
Wheel Cylinder Pressure Sensors	These sensors detect the fluid pressure that acts on the respective wheel cylinders and transmits them to the skid control ECU in the form of feedback. Accordingly, the skid control ECU monitors the fluid pressure of the wheel cylinders and controls the pressure appliance solenoid valve and the pressure reduction solenoid valve, in order to achieve the optimal wheel cylinder pressures.
Accumulator Pressure Sensor	The accumulator pressure sensor constantly detects the brake fluid pressure in the accumulator and transmits the signals to the skid control ECU. Accordingly, the skid control ECU controls the pump motor.
Pump and Pump Motor	Draws up the brake fluid from the reservoir tank and provides high hydraulic pressure to the accumulator.
Accumulator	Stores the hydraulic pressure that was generated by the pump. The accumulator is filled with high pressure nitrogen gas.
Relief Valve	Returns the brake fluid to the reservoir tank to prevent excessive pressure if the pump operates continuously due to a malfunction of the accumulator pressure sensor.

### b. Hydraulic Control Portion

The 10 solenoid valves and 6-pressure sensors consists of the following:

- 2 master cylinder cut solenoid valves [(1), (2)]
- 4 pressure appliance valves [(3), (4), (5), (6)]
- 4 pressure reduction valves [(7), (8), (9), (10)]
- 2 master cylinder pressure sensors [(a), (b)]
- 4 wheel cylinder pressure sensors [(c), (d), (e), (f)]

#### ► Hydraulic Circuit ◀

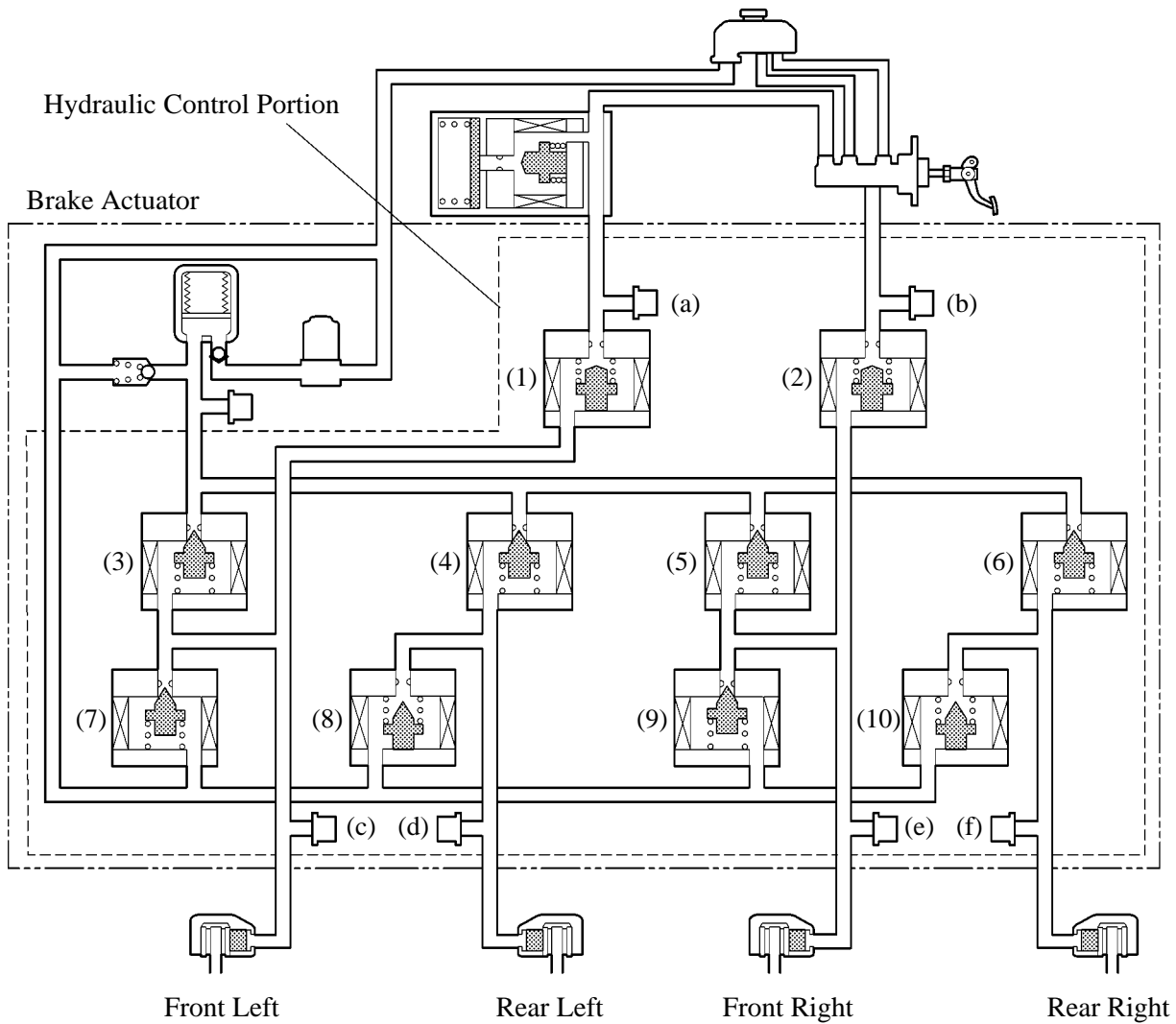

### c. Hydraulic Power Source Portion

#### i) General

The hydraulic power source portion consists of pump, pump motor, accumulator, relief valve, 2 motor relays, and accumulator pressure sensor.

#### ii) Accumulator

Inside the accumulator, the high-pressurized nitrogen gas is charged and sealed. In addition, metallic bellows-formed tube is used, in order to enhance the gastight performance of the accumulator.

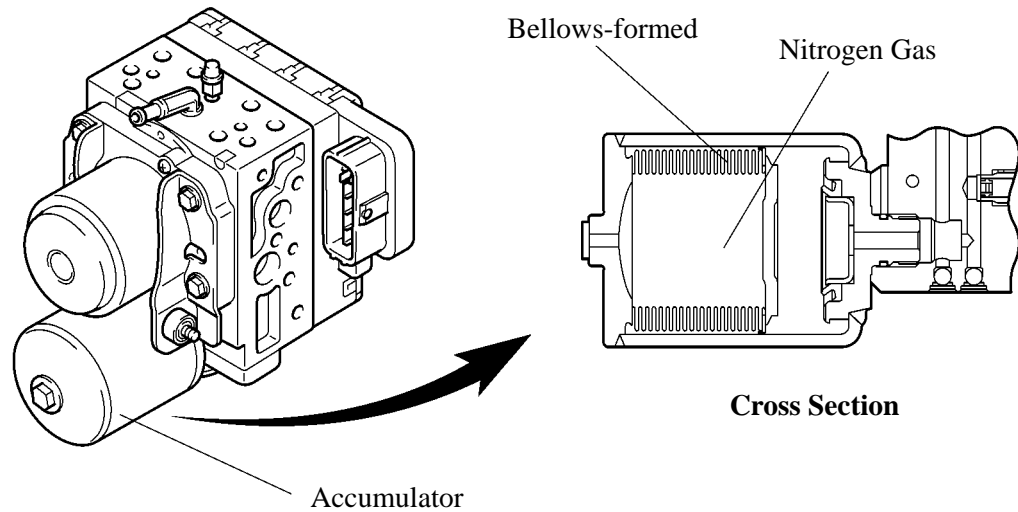

02HCH14Y

#### iii) Pump and Pump Motor

A plunger type pump is used. This pump is operated by the rotation of the camshaft driven by the motor, and then supplies high-pressurized fluid to the accumulator.

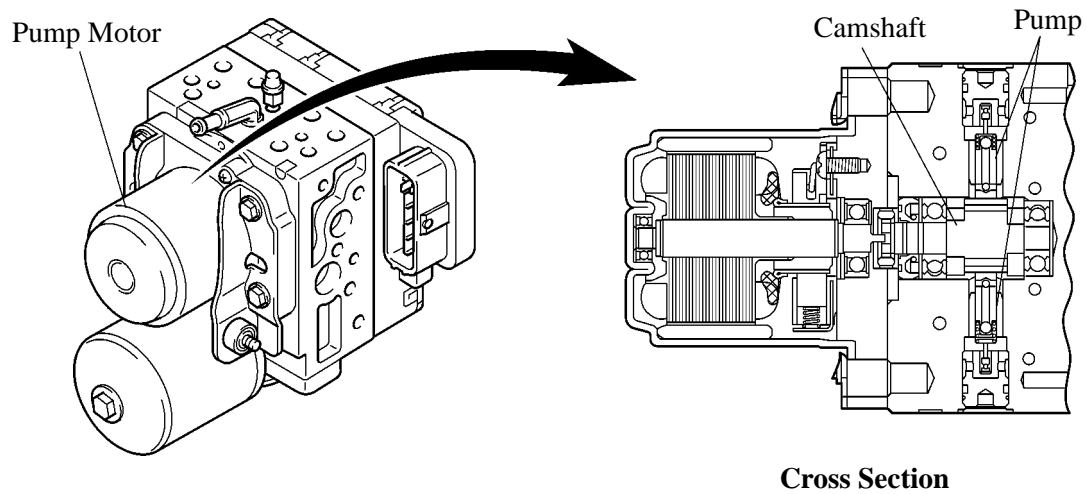

02HCH15Y

iv) Operation

- The brake fluid that is discharged by the pump passes through the check valve and is stored in the accumulator. The hydraulic pressure that is stored in the accumulator is used for providing the hydraulic pressure that is needed for normal braking and for operating the brake control.
- The motor relays consist of the following relays with different pump actuation speeds: relay 1 (low speed) and relay 2 (high speed). Normally, relay 1 with the slow pump speed is used. When the fluid pressure drops quickly because more fluid pressure is required, such as in ABS fluid pressure control, relay 2 with the fast pump speed is used. If one of the relays malfunctions, the other is used for actuating the pump.
- The accumulator pressure sensor constantly monitors the pressure in the accumulator and transmits it to the skid control ECU. If the accumulator pressure drops below the set pressure, the skid control ECU sends an activation signal to the motor relay in order to actuate the pump motor until the pressure in the accumulator reaches the set pressure.

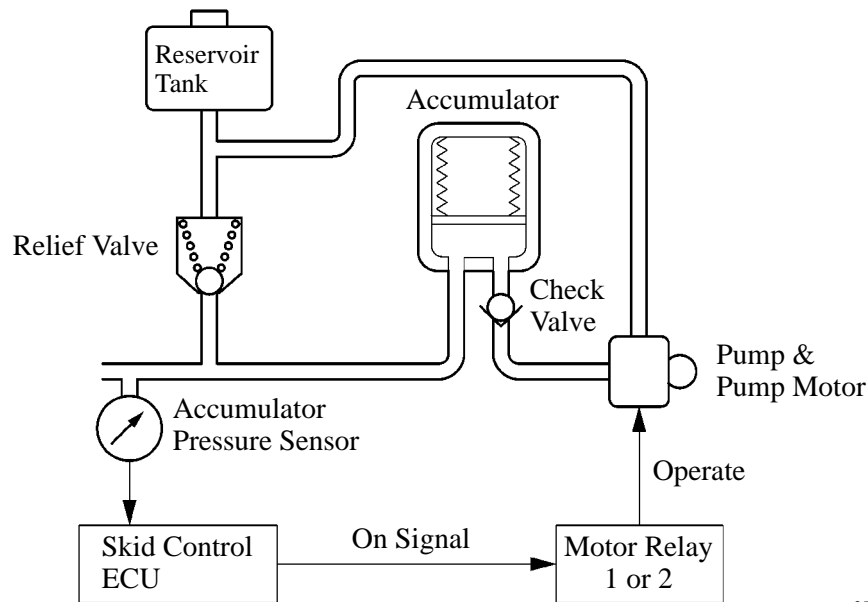

255CH136

- If the pump and the pump motor continue to operate unintendedly, and the accumulator sensor failed, a high pressure would be created in the accumulator. At this time, the relief valve will open. To return the brake fluid to the reservoir tank, to reduce the accumulator pressure.

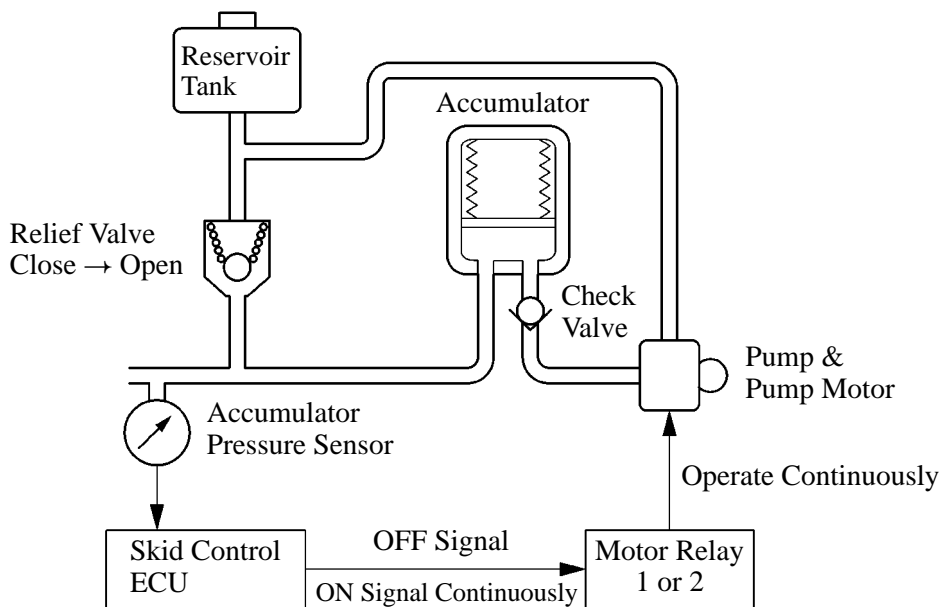

02HCH28Y



- If the accumulator pressure drops abnormally to a level below the pressure set at the ECU, the skid control ECU illuminates the brake system warning light, the ECB\* warning light, ABS warning light and the master warning light. Then, a warning message appears on the multi-information display in the combination meter, and the VSC warning buzzer sounds to alert the driver of the abnormal hydraulic pressure.

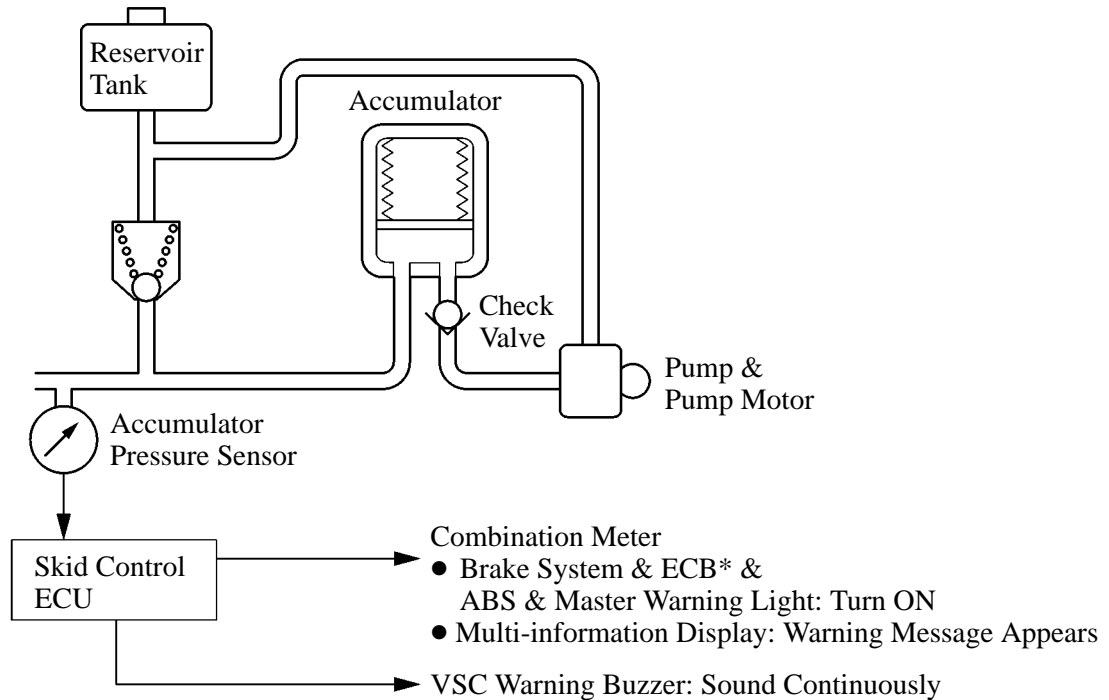

255CH138

\*: ECB (Electronically Controlled Brake System)

## 2) Brake Pedal Stroke Sensor

This sensor, which contains a contact type variable resistor, detects the extent of the brake pedal stroke and transmits it to the skid control ECU.

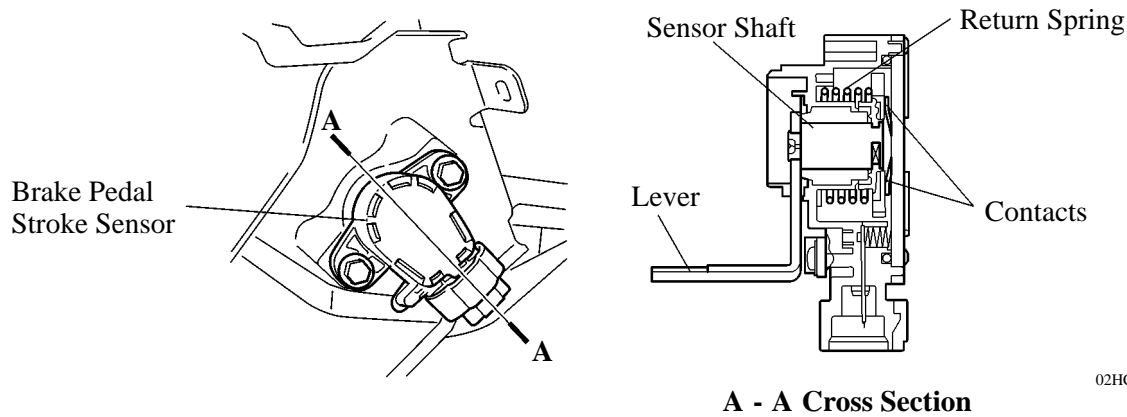

02HCH16Y

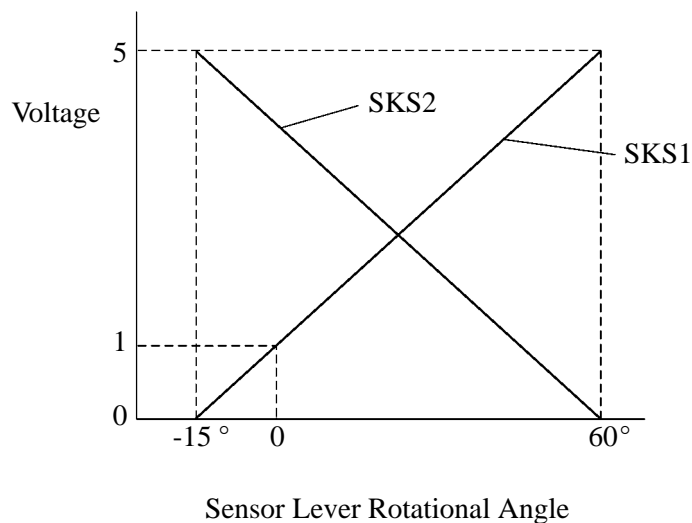

255CH164

### Service Tip

- To install a brake pedal stroke sensor, which is available as a service part, perform as follows:
  - The sensor lever is secured with a pin to "0" stroke. (Do not detach the pin until the installation has been completed.)
  - In this state, install the sensor on the brake pedal (in the OFF state) on the vehicle.
  - After completing the installation, firmly press the brake pedal once to break off the pin that is securing the sensor in place.
  - Make sure the broken pin does not remain in the sensor lever.
- After replacing the brake pedal stroke sensor, initialization of brake pedal stroke sensor must be required on the skid control ECU side.
- For the actual procedure, refer to the 2007 Camry Hybrid Vehicle Repair Manual (Pub. No. RM02H0U).

### 3) Stroke Simulator

- The stroke simulator is mounted between the master cylinder and the brake actuator. The fluid pressure generated by the master cylinder is introduced to the stroke simulator through the built-in stroke simulator cut valve.
- The stroke simulator generates a pedal stroke in accordance with the driver's pedal effort during braking. Containing two types of coil springs with different spring constants, the stroke simulator provides pedal stroke characteristics in two stages in relation to the master cylinder pressure.

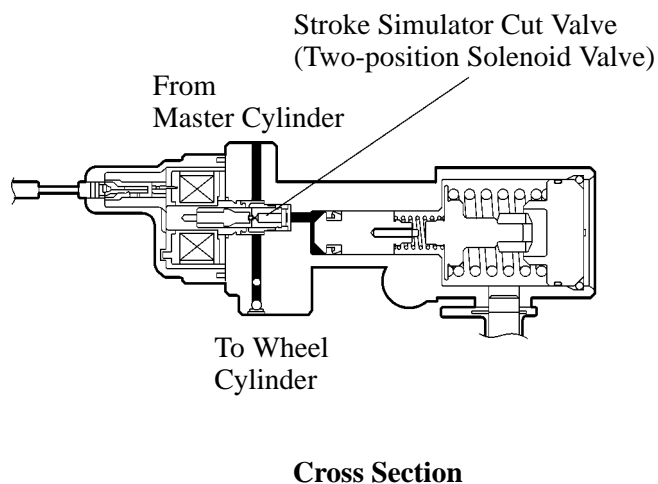
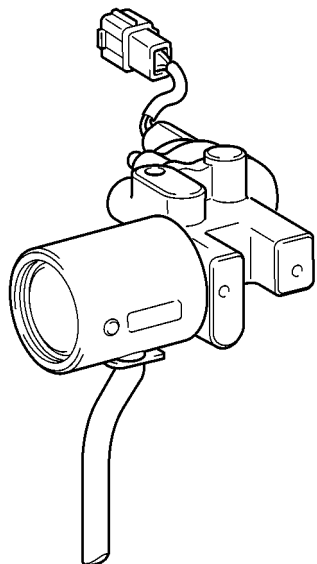

02HCH18Y

### 4) Yaw Rate and Deceleration Rate Sensor

A deceleration rate sensor is built into the yaw rate sensor. This sensor detects the yaw rate and lateral acceleration, and sends this signal to the skid control ECU.

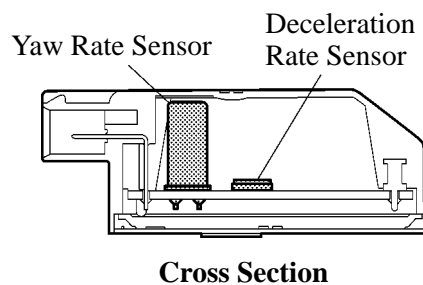

02HCH17TE

#### Service Tip

After replacing the yaw rate and deceleration rate sensor, or the skid control ECU, initialization of the yaw rate and deceleration rate sensor is required.

For the actual procedure, refer to the 2007 Camry Hybrid Vehicle Repair Manual (Pub. No. RM02H0U).

### 5) Steering Angle Sensor

- The steering angle sensor detects the steering direction and angle, and sends this signal to the skid control ECU.
- The sensor contains two gears for detecting the rotational movement. The magnetic field of the MRE (Magnetic Resistance Element), which is built into these gears, changes as the gears rotate. The change in the magnetic field causes the resistance of the sensor to change, which is detected by the skid control ECU in the form of the rotational angle of the steering.

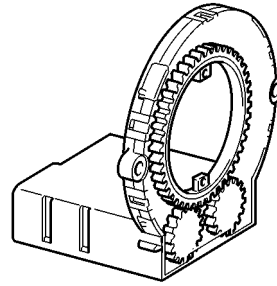

02HCH19Y

### 6) Power Source Backup Unit

- The power source backup unit is used as an auxiliary power source, in order to supply power to the brake system in a stable manner.
- This unit contains 12 capacitor cells, which store an electrical charge provided by the (12 V) vehicle power supply. When the voltage of the (12 V) vehicle power supply drops, the electrical charge stored in the capacitor cells is used as an auxiliary power supply to the brake system.

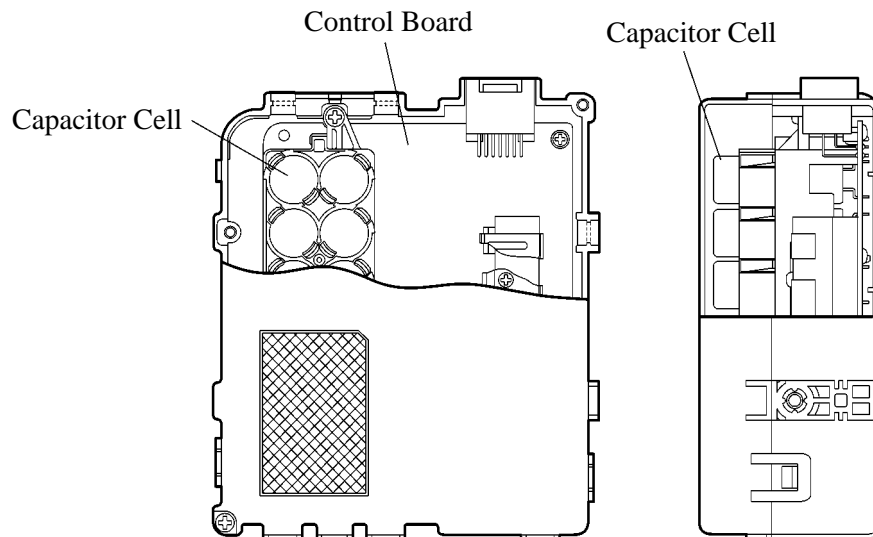

02HCH20TE

#### Service Tip

Immediately after the power switch is turned OFF, this unit is in the discharging state, and some voltage remains in the capacitors. Therefore, make sure to check for residual voltage and discharge it if necessary, before removing the power source backup unit from the vehicle or opening and inspecting the inside of the power source backup unit case.

For details, refer to the 2007 Camry Hybrid Vehicle Repair Manual (Pub. No. RM02H0U).

## System Operation

### 1) Normal Brake Operation (with Regenerative Brake Cooperative Control)

#### a. General

- During normal braking, the master cylinder cut solenoid valves are closed and the fluid pressure circuits to the wheel cylinders remain independent. Accordingly, the fluid pressure generated by the master cylinder will not directly cause the wheel cylinders to actuate.
- The skid control ECU calculates the braking force required by the driver in accordance with the signals received from the master cylinder pressure sensors and the brake pedal stroke sensor. Then, the skid control ECU calculates the regenerative brake force value out of the required brake force and transmits the calculated value to the THS ECU. Upon receiving the value, the THS ECU generates a regenerative brake force. At the same time, the THS ECU transmits the actual regenerative brake force value to the skid control ECU. The skid control ECU controls the solenoid valves in order to cause the hydraulic brake system to generate a brake force value (which is obtained by subtracting the regenerative brake force from the brake force value required by the driver).

#### ► System Diagram ◀

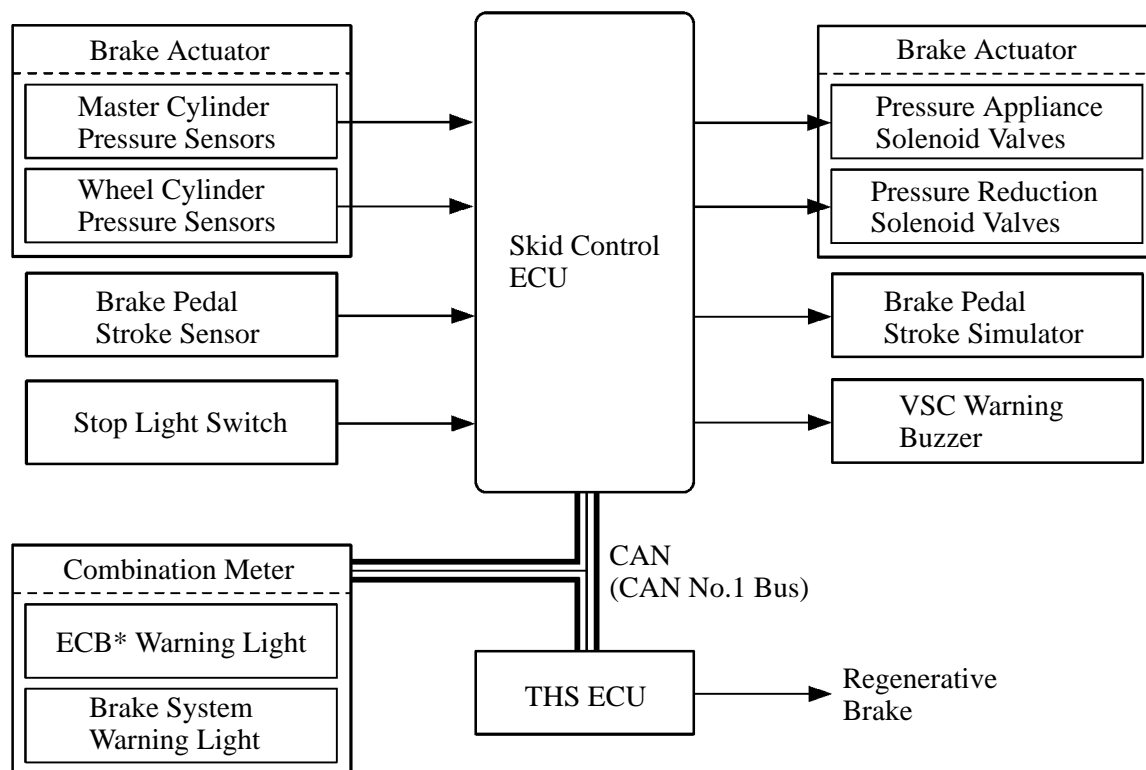

02HCH21P

\*: ECB (Electronically Controlled Brake System)

**b. Pressure Increase**

The skid control ECU calculates the target wheel cylinder pressure (equivalent to the brake force required by the driver) in accordance with the signals received from the master cylinder pressure sensor and the brake pedal stroke sensor. The skid control ECU compares the wheel cylinder pressure sensor signal and the target wheel cylinder pressure. If the target wheel cylinder pressure is lower, the skid control ECU boosts the pressure in the brake actuator. Accordingly, the fluid pressure in the accumulator is fed into the wheel cylinder. Moreover, this operation is the same when the hydraulic brake force must be increased in order to effect cooperative control in accordance with the changes in the regenerative brake force.

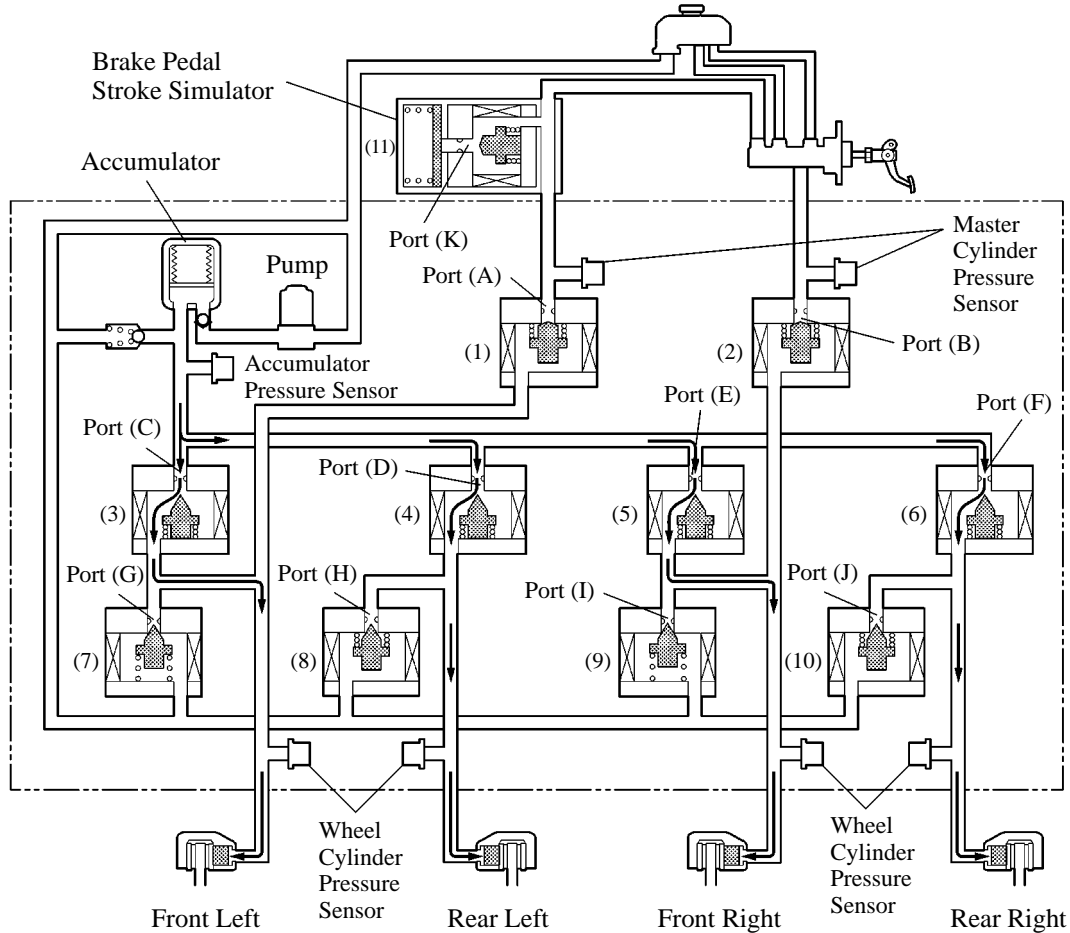

256CH108

Item		Normal Braking Increase Mode
(1), (2)	Master Cylinder Cut Solenoid Valve	ON (Close)
	Port: (A), (B)	
(3), (4), (5), (6)	Pressure Appliance Solenoid Valve	ON (Half-Open*)
	Port: (C), (D), (E), (F)	
(7), (9)	Pressure Reduction Solenoid Valve	OFF (Close)
	Port: (G), (I)	
(8), (10)	Pressure Reduction Solenoid Valve	ON (Close)
	Port: (H), (J)	
(11)	Stroke Simulator Cut Solenoid Valve	ON (Open)
	Port: (K)	

\*: The solenoid valve constantly regulates the amount of opening of the port in accordance with the use conditions in order to control the fluid pressure.

**c. Holding**

The skid control ECU calculates the target wheel cylinder pressure (equivalent to the brake force required by the driver) in accordance with the signals received from the master cylinder pressure sensor and the brake pedal stroke sensor.

The skid control ECU compares the wheel cylinder pressure signal with the target wheel cylinder pressure. If they are equal, the skid control ECU controls the brake actuator in the hold state.

Accordingly, the wheel cylinder will be held at a constant pressure.

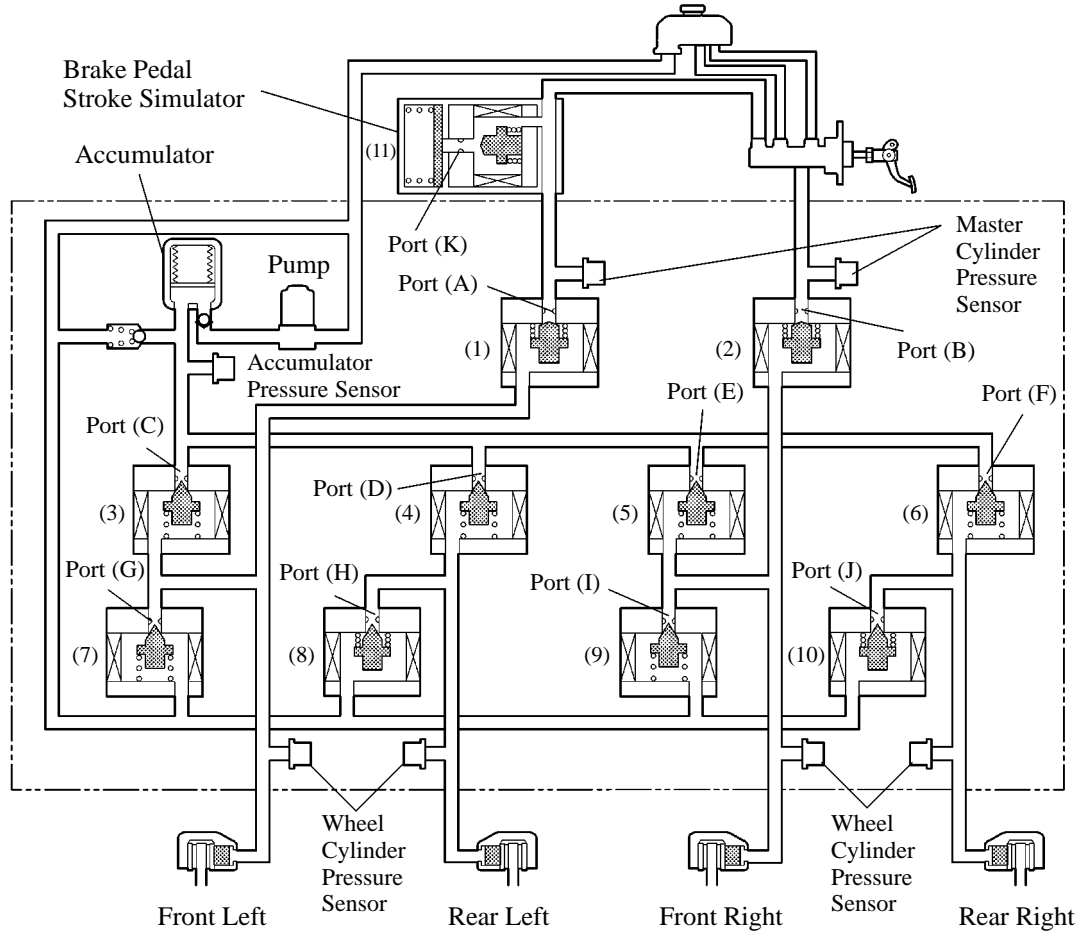

256CH109

Item		Normal Braking Holding Mode
(1), (2)	Master Cylinder Cut Solenoid Valve Port: (A), (B)	ON (Close)
(3), (4), (5), (6)	Pressure Appliance Solenoid Valve Port: (C), (D), (E), (F)	OFF (Close)
(7), (9)	Pressure Reduction Solenoid Valve Port: (G), (I)	OFF (Close)
(8), (10)	Pressure Reduction Solenoid Valve Port: (H), (J)	ON (Close)
(11)	Stroke Simulator Cut Solenoid Valve Port: (K)	ON (Open)

**d. Pressure Reduce**

The skid control ECU calculates the target wheel cylinder pressure (equivalent to the brake force required by the driver) in accordance with the signals received from the master cylinder pressure sensor and the brake pedal stroke sensor.

The skid control ECU compares the wheel cylinder pressure signal with the target wheel cylinder pressure. If the target wheel cylinder pressure is higher, the skid control ECU reduces the pressure in the brake actuator. Accordingly, the pressure in the wheel cylinder decreases.

Moreover, this operation is the same when the hydraulic brake force must be decreased in order to effect cooperative control in accordance with the changes in the regenerative brake force.

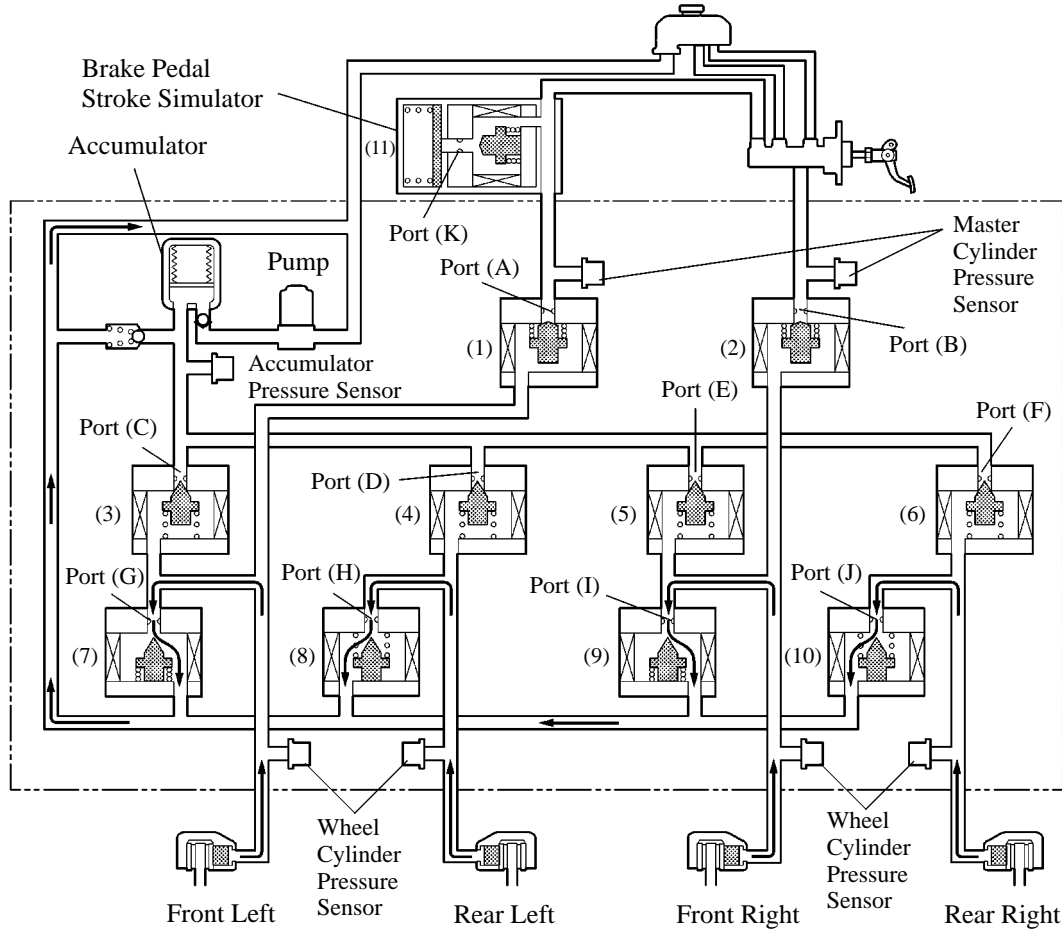

256CH110

Item		Normal Braking Reduction Mode
(1), (2)	Master Cylinder Cut Solenoid Valve Port: (A), (B)	ON (Close)
(3), (4), (5), (6)	Pressure Appliance Solenoid Valve Port: (C), (D), (E), (F)	OFF (Close)
(7), (9)	Pressure Reduction Solenoid Valve Port: (G), (I)	ON (Half-Open*)
(8), (10)	Pressure Reduction Solenoid Valve Port: (H), (J)	ON (Half-Open*)
(11)	Stroke Simulator Cut Solenoid Valve Port: (K)	ON (Open)

\*: The solenoid valve constantly regulates the amount of opening of the port in accordance with the use conditions in order to control the fluid pressure.



**e. Brake System Stops or During Power Supply Malfunction**

If the brake system stops or no accumulator pressure is supplied due to some malfunction, the skid control ECU operates the fail-safe function. This function opens the master cylinder solenoid valve in the brake actuator, in order to secure a fluid passage between the master cylinder and the wheel cylinder. Thus, the brakes can be applied by operating only the front wheel cylinders under the fluid pressure generated by the master cylinder. At this time, port (K) of the stroke simulator cut solenoid valve closes in order to prevent the fluid pressure generated by the master cylinder from being negatively affected by the operation of the stroke simulator.

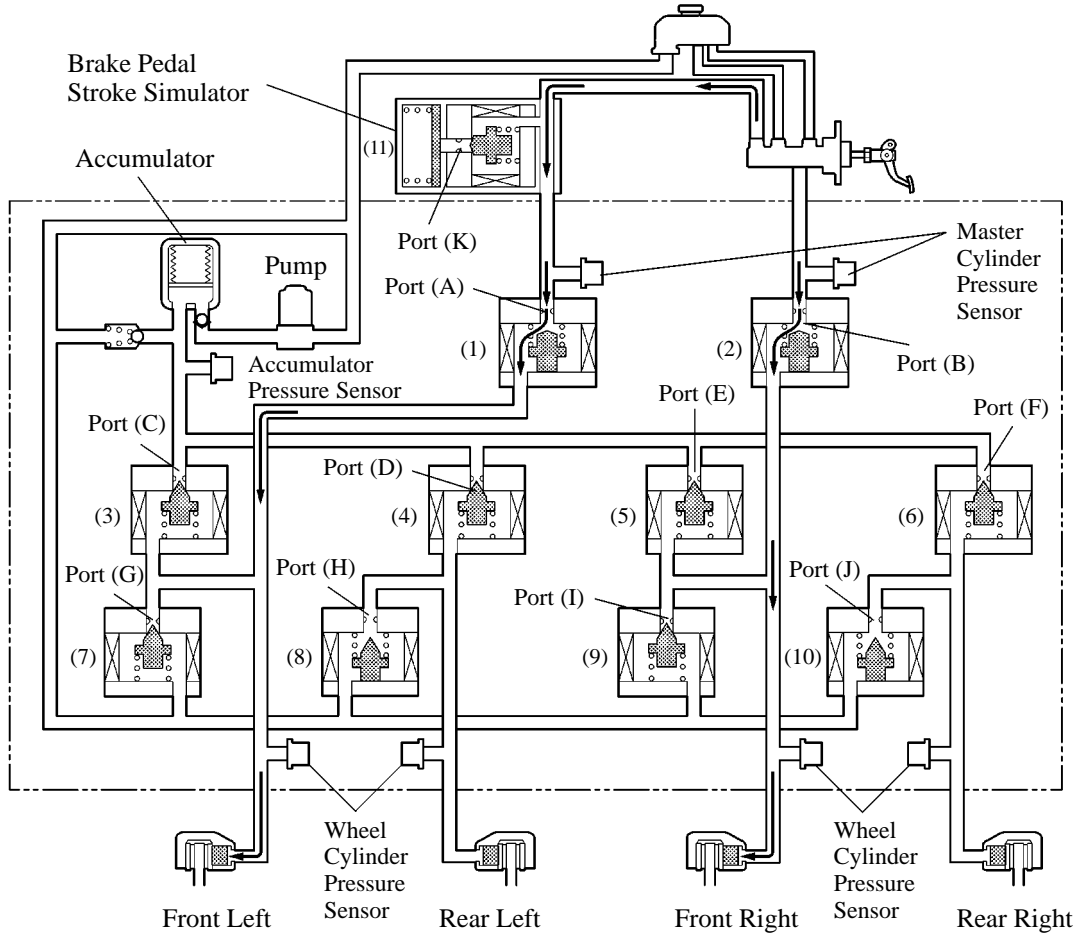

256CH111

Item		System OFF & Fail-Safe Mode
(1), (2)	Master Cylinder Cut Solenoid Valve	OFF (Open)
	Port: (A), (B)	
(3), (4), (5), (6)	Pressure Appliance Solenoid Valve	OFF (Close)
	Port: (C), (D), (E), (F)	
(7), (9)	Pressure Reduction Solenoid Valve	OFF (Close)
	Port: (G), (I)	
(8), (10)	Pressure Reduction Solenoid Valve	OFF (Open)
	Port: (H), (J)	
(11)	Stroke Simulator Cut Solenoid Valve	OFF (Close)
	Port: (K)	

2) ABS with EBD Operation

Based on the signals received from the four speed sensors, the skid control ECU calculates each wheel speed and deceleration, and checks wheel slipping conditions. And according to the slipping condition, the skid control ECU controls the pressure increase valve and pressure reduction valve in order to adjust the fluid pressure of the each wheel cylinder in the following 3 modes: pressure reduction, pressure holding, pressure increase modes.

► System Diagram ◀

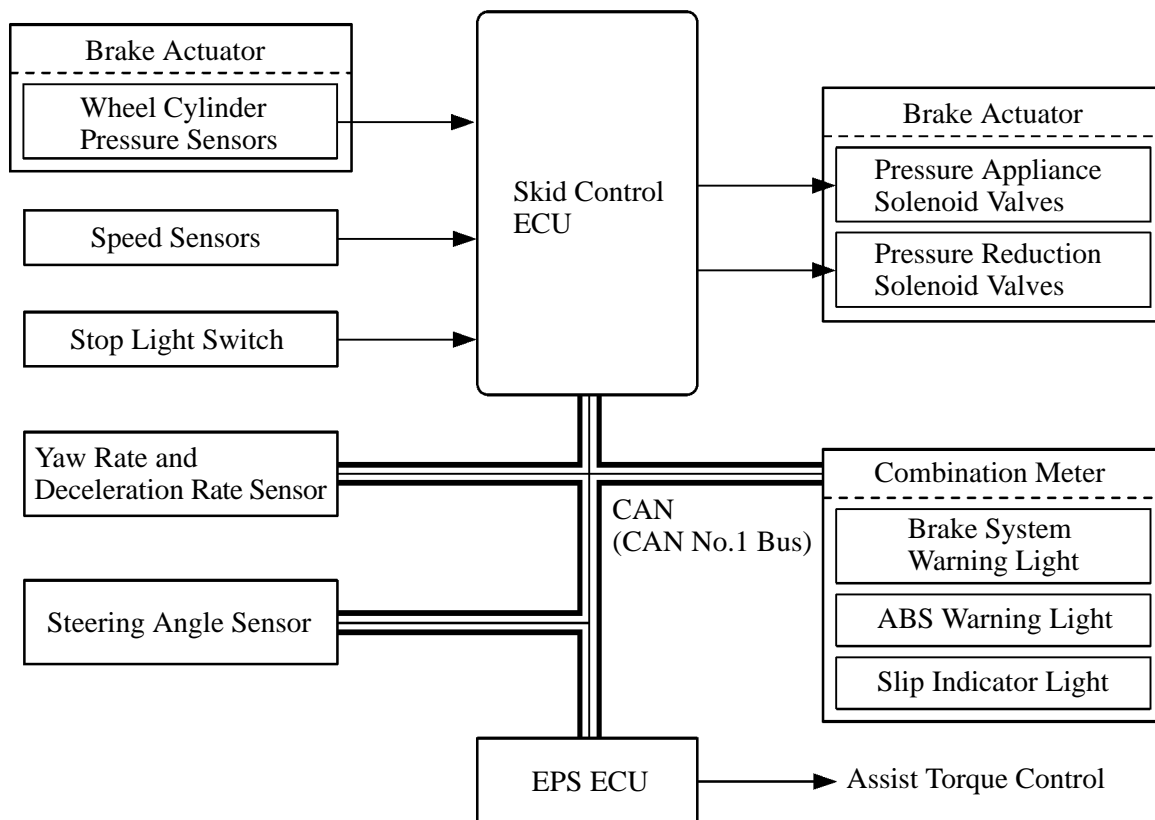

Not Activated		Normal Braking	—	—								
Activated		Increase Mode	Holding Mode	Reduction Mode								
Hydraulic Circuit		<p>To Wheel Cylinder</p> <p>255CH151</p>	<p>255CH152</p>	<p>To Reservoir</p> <p>From Wheel Cylinder</p> <p>255CH153</p>								
		<table border="1"> <tr> <td rowspan="2">Front</td> <td>Pressure Appliance Solenoid Valve (Port A)</td> <td>ON (Half-Open*)</td> <td>OFF (Close)</td> <td>OFF (Close)</td> </tr> <tr> <td>Pressure Reduction Solenoid Valve (Port B)</td> <td>OFF (Close)</td> <td>OFF (Close)</td> <td>ON (Half-Open*)</td> </tr> </table>	Front	Pressure Appliance Solenoid Valve (Port A)	ON (Half-Open*)	OFF (Close)	OFF (Close)	Pressure Reduction Solenoid Valve (Port B)	OFF (Close)	OFF (Close)	ON (Half-Open*)	
Front	Pressure Appliance Solenoid Valve (Port A)	ON (Half-Open*)		OFF (Close)	OFF (Close)							
	Pressure Reduction Solenoid Valve (Port B)	OFF (Close)	OFF (Close)	ON (Half-Open*)								
Hydraulic Circuit		<p>To Wheel Cylinder</p> <p>255CH159</p>	<p>255CH160</p>	<p>To Reservoir</p> <p>From Wheel Cylinder</p> <p>255CH161</p>								
		<table border="1"> <tr> <td rowspan="2">Rear</td> <td>Pressure Appliance Solenoid Valve (Port A)</td> <td>ON (Half-Open*)</td> <td>OFF (Close)</td> <td>OFF (Close)</td> </tr> <tr> <td>Pressure Reduction Solenoid Valve (Port B)</td> <td>ON (Close)</td> <td>ON (Close)</td> <td>ON (Half-Open*)</td> </tr> </table>	Rear	Pressure Appliance Solenoid Valve (Port A)	ON (Half-Open*)	OFF (Close)	OFF (Close)	Pressure Reduction Solenoid Valve (Port B)	ON (Close)	ON (Close)	ON (Half-Open*)	
Rear	Pressure Appliance Solenoid Valve (Port A)	ON (Half-Open*)		OFF (Close)	OFF (Close)							
	Pressure Reduction Solenoid Valve (Port B)	ON (Close)	ON (Close)	ON (Half-Open*)								
Wheel Cylinder Pressure		Increase	Hold	Reduction								

\*: The solenoid valve constantly regulates the amount of opening of the port in accordance with the use conditions in order to control the fluid pressure.

3) Brake Assist Operation

In the event of emergency braking, the skid control ECU detects the driver’s intention based on the speed of the pressure increase in the master cylinder determined by the pressure sensor signal. If the ECU judges the need for the additional brake assist, additional fluid pressure is generated by the pump in the actuator and directed to the wheel cylinders.

► System Diagram ◀

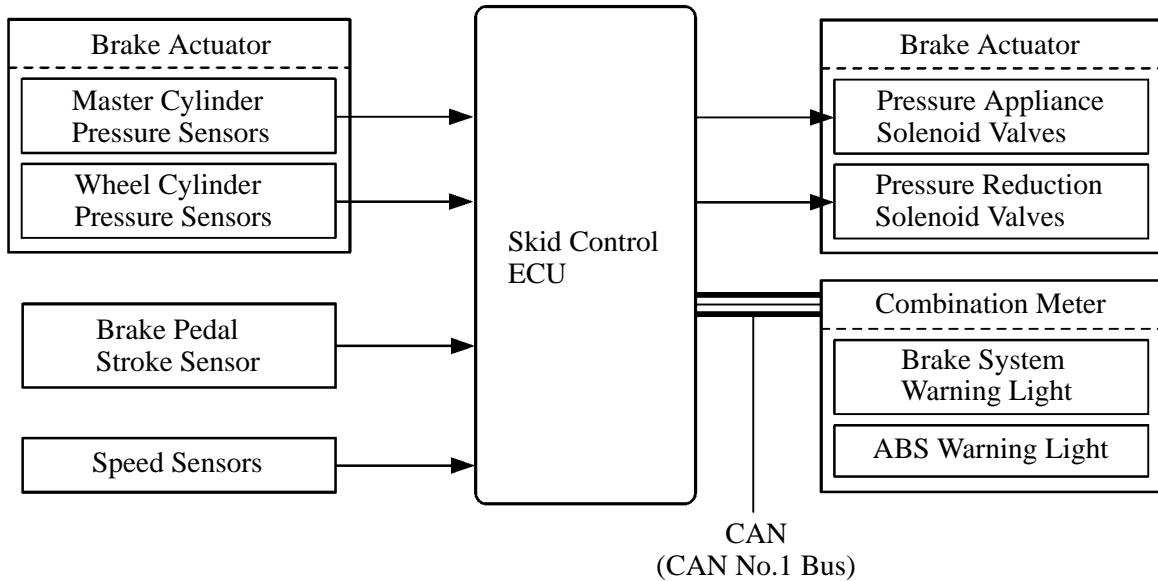

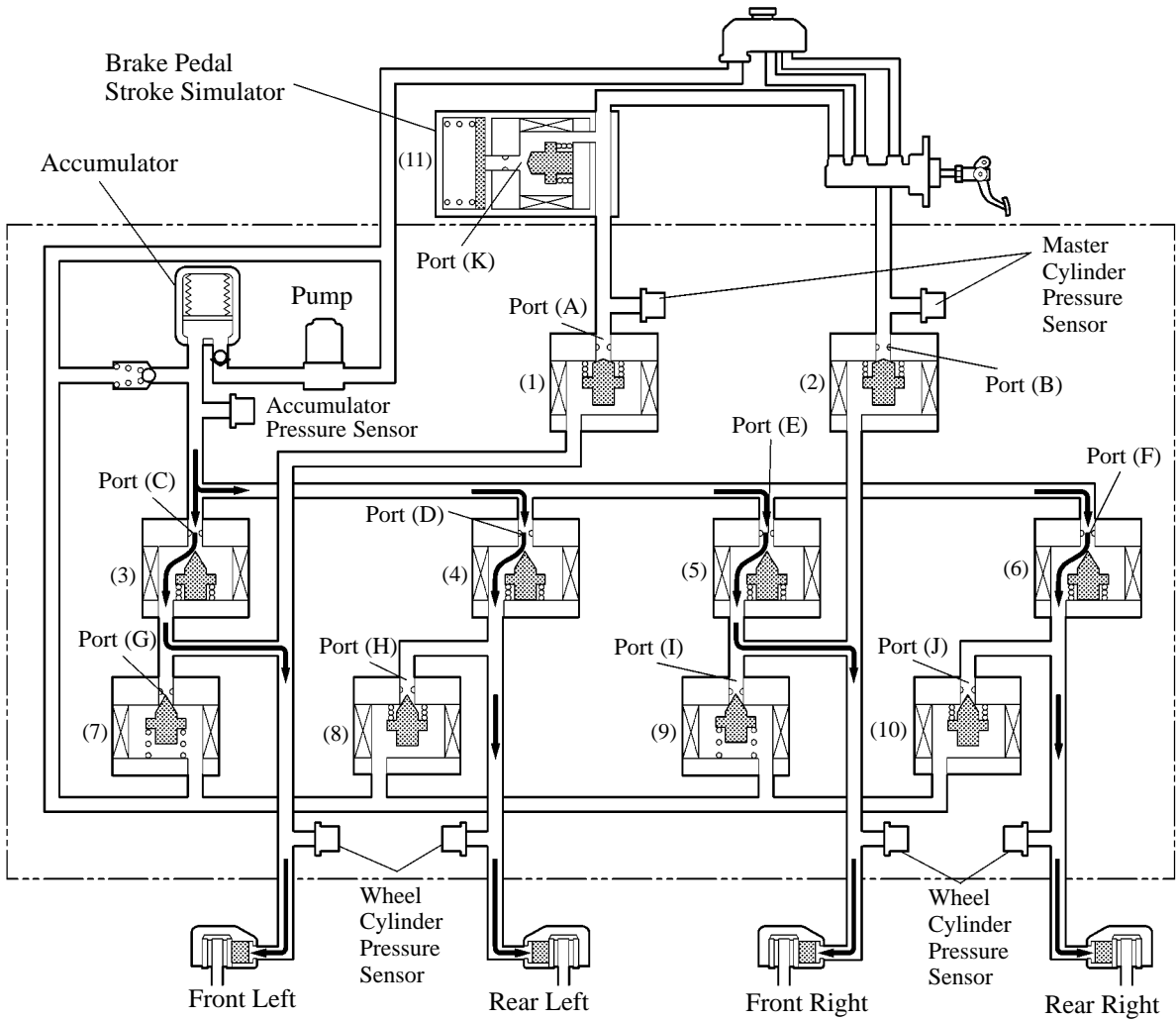

256CH112

Item		Normal Braking Increase Mode	Brake Assist Activated
(1), (2)	Master Cylinder Cut Solenoid Valve Port: (A), (B)	ON (Close)	ON (Close)
(3), (4), (5), (6)	Pressure Appliance Solenoid Valve Port: (C), (D), (E), (F)	ON (Half-Open*)	ON (Half-Open*)
(7), (9)	Pressure Reduction Solenoid Valve Port: (G), (I)	OFF (Close)	OFF (Close)
(8), (10)	Pressure Reduction Solenoid Valve Port: (H), (J)	ON (Close)	ON (Close)
(11)	Stroke Simulator Cut Solenoid Valve Port: (K)	ON (Open)	ON (Open)

\*: The solenoid valve constantly regulates the amount of opening of the port in accordance with the use conditions in order to control the fluid pressure.

#### 4) TRAC Operation

- The fluid pressure generated by the pump is regulated by the pressure appliance solenoid valve and pressure reduction solenoid valve to the required pressure. Thus, the wheel cylinders of the drive wheels are controlled in the following 3 modes: pressure reduction, pressure holding, and pressure increase modes, to restrain the slippage of the drive wheels.
- The pressure appliance valve and the pressure reduction valve are turned ON/OFF according to the ABS operation pattern.
- The diagram on the next page shows the hydraulic circuit in the pressure increase mode when the TRAC function is activated.

#### ► System Diagram ◀

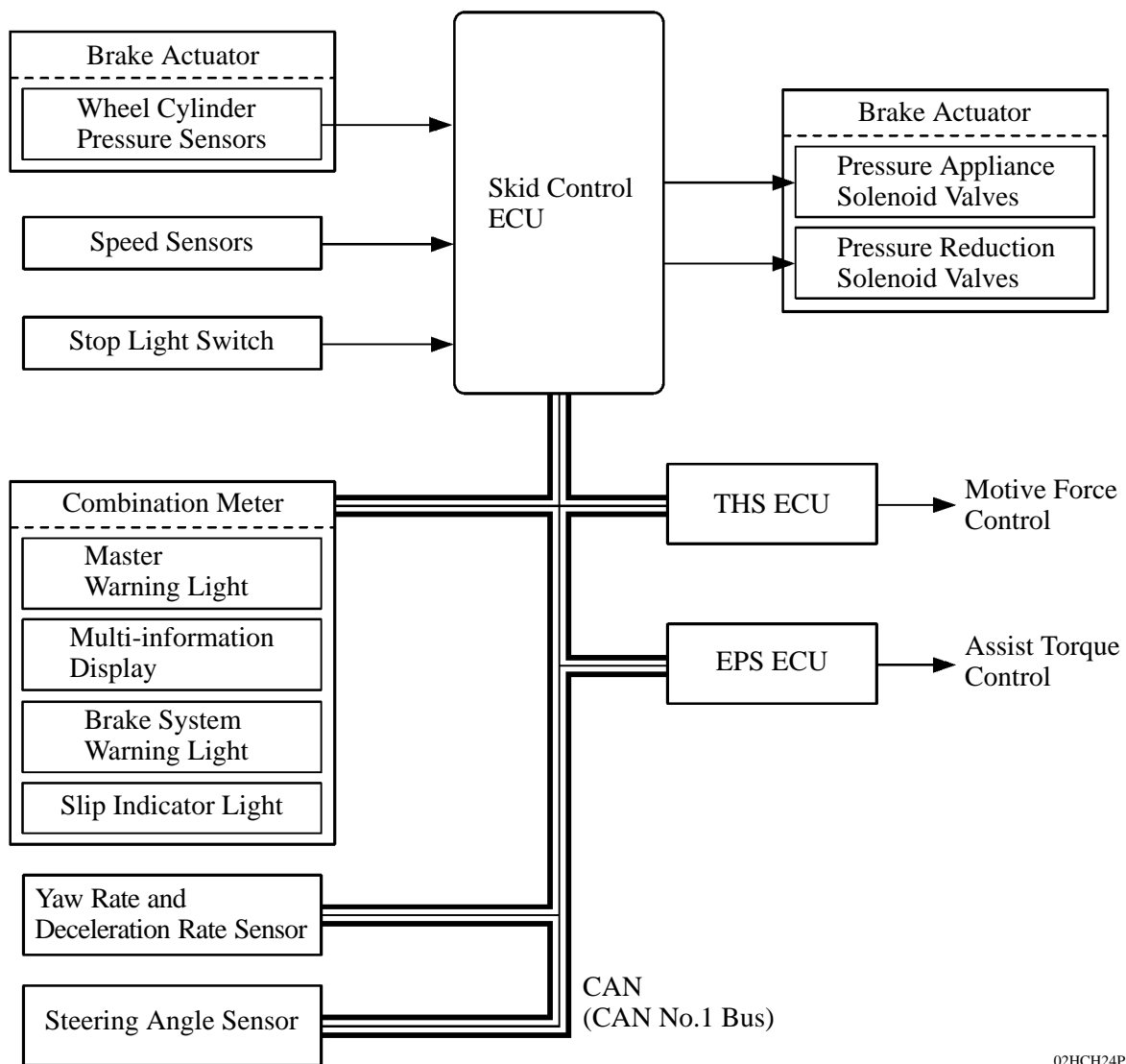

02HCH24P

#### Service Tip

A service mode has been created for '07 Camry Hybrid model. In this mode, TRAC and VSC functions can be forcibly turned OFF, either through the operation of a hand-held tester or by operating the shift lever and depressing the accelerator pedal.

For details, refer to the 2007 Camry Hybrid Vehicle Repair Manual (Pub. No. RM02H0U).

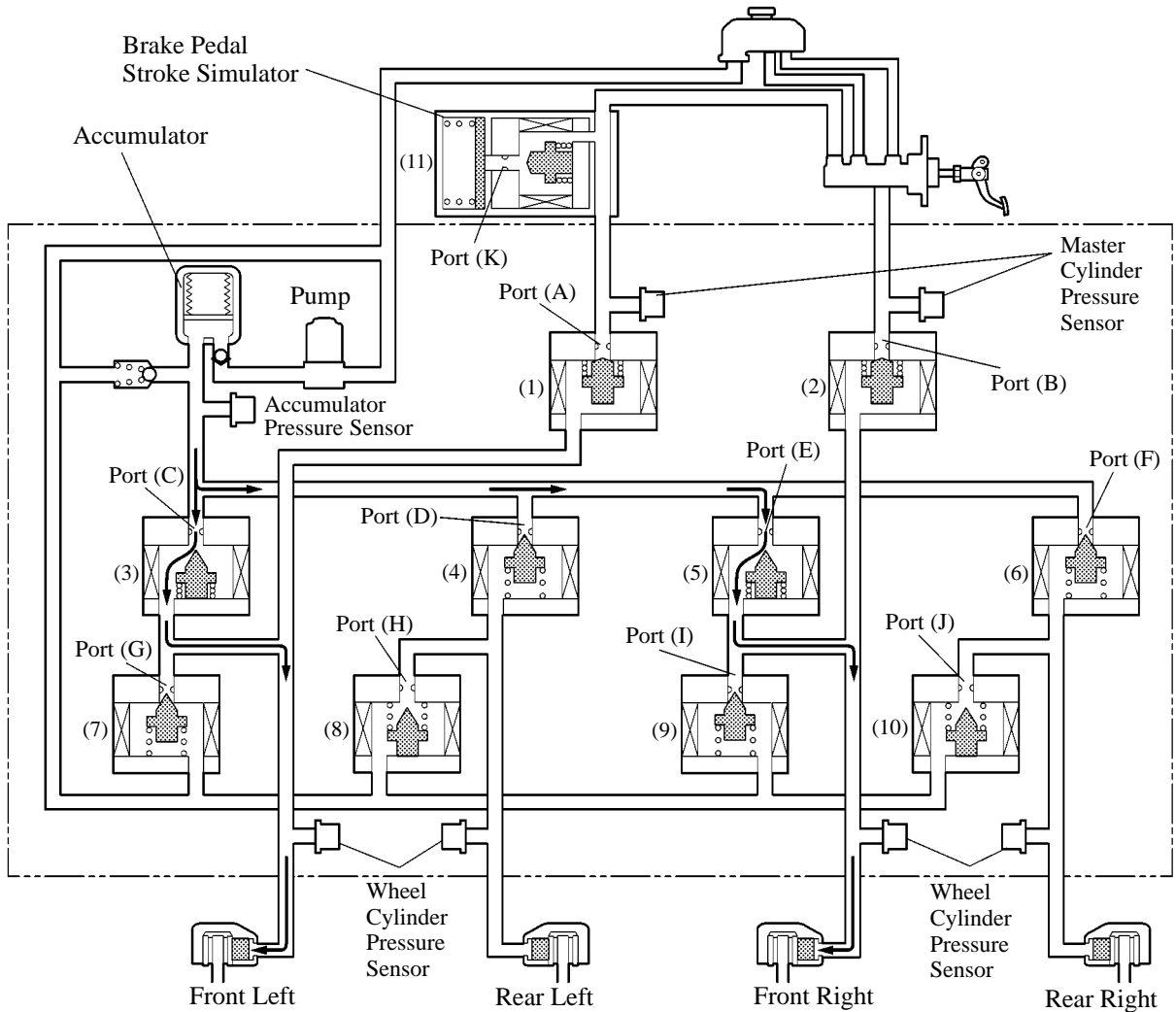

**Increase Mode**

277CH155

Item		TRAC not Activated	TRAC Activated		
			Increase Mode	Holding Mode	Reduction Mode
(1), (2)	Master Cylinder Cut Solenoid Valve	ON (Close)	ON (Close)	ON (Close)	ON (Close)
	Port: (A), (B)				
Front Brake	(3), (5)	OFF (Close)	ON (Half-Open*)	OFF (Close)	OFF (Close)
	(7), (9)	OFF (Close)	OFF (Close)	OFF (Close)	ON (Half-Open*)
Wheel Cylinder Pressure		—	Increase	Hold	Reduction
Rear Brake	(4), (6)	OFF (Close)	OFF (Close)	OFF (Close)	OFF (Close)
	(8), (10)	OFF (Open)	OFF (Open)	OFF (Open)	OFF (Open)
Wheel Cylinder Pressure		—	—	—	—
(11)	Stroke Simulator Cut Solenoid Valve	ON (Open)	ON (Open)	ON (Open)	ON (Open)
	Port: (K)				

\*: The solenoid valve constantly regulates the amount of opening of the port in accordance with the use conditions in order to control the fluid pressure.

5) VSC Operation

a. General

The VSC function controls the solenoid valves in order to send the fluid pressure stored in the accumulator to the brake wheel cylinders at the respective wheels, through routes that are different from those used during normal braking. Thus, the function operates in the following 3 modes: pressure reduction, pressure holding, and pressure increase. As a result, the tendency of the front wheels or the rear wheels to skid is restrained.

► System Diagram ◀

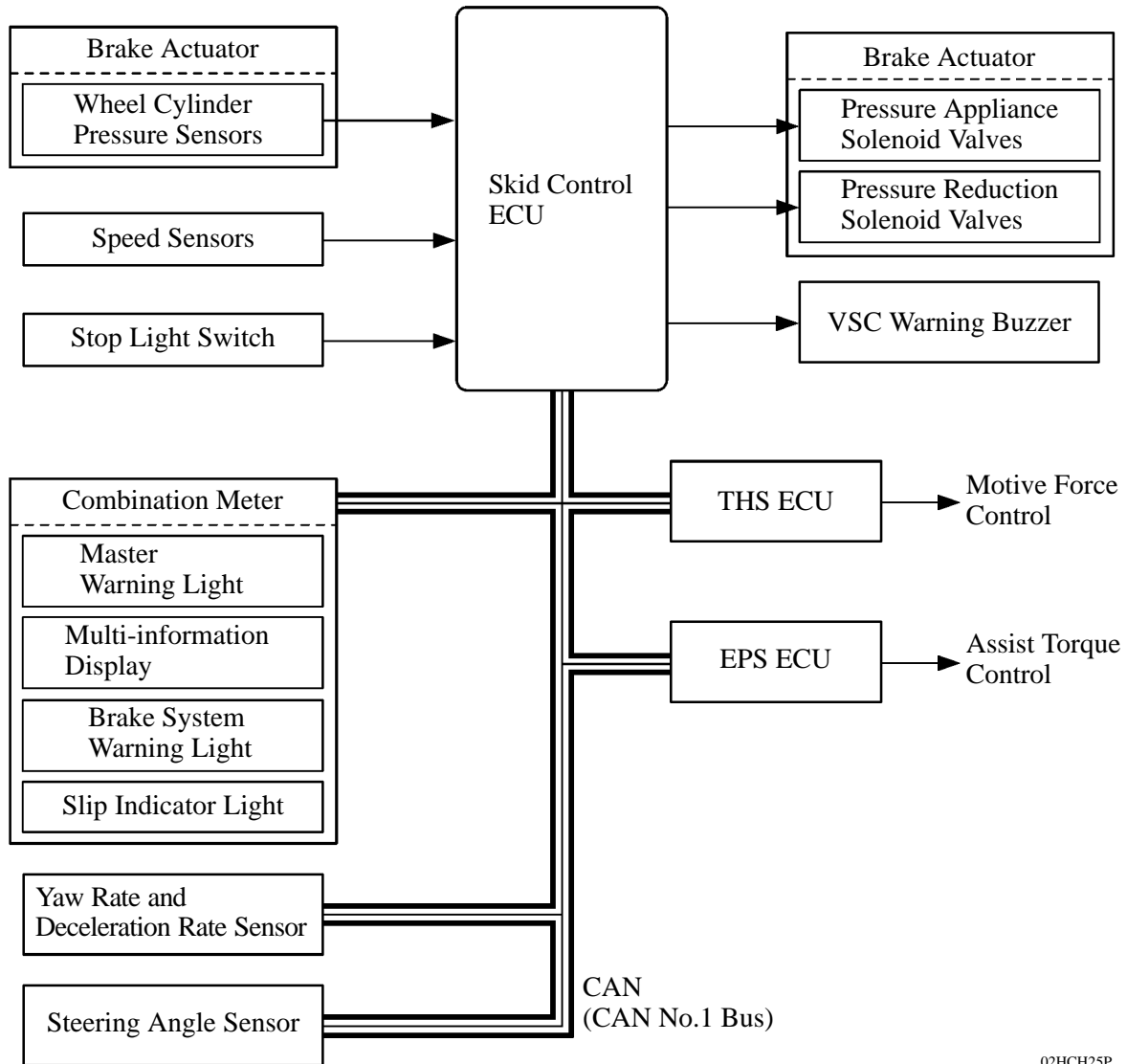

02HCH25P

**Service Tip**

A service mode has been created for '07 Camry Hybrid model. In this mode, TRAC and VSC functions can be forcibly turned OFF, either through the operation of a hand-held tester or by operating the shift lever and depressing the accelerator pedal.

For details, refer to the 2007 Camry Hybrid Vehicle Repair Manual (Pub. No. RM02H0U).



**b. Front Wheel Skid Restraint Control (Turning to the Right)**

- In the front wheel skid tendency, this management function applies the brake to the rear wheels and front wheel of the outer side of the turn. Also, depending on whether the brake is ON or OFF and the condition of the vehicle, there are circumstances in which the brake might not be applied to the wheels even if those wheels are targeted for braking. The diagram below shows the hydraulic circuit in the pressure increase mode, as it restrains the front wheel skid condition while the vehicle makes a right turn.
- The pressure appliance valve and the pressure reduction valve are turned ON/OFF according to the ABS operation pattern.

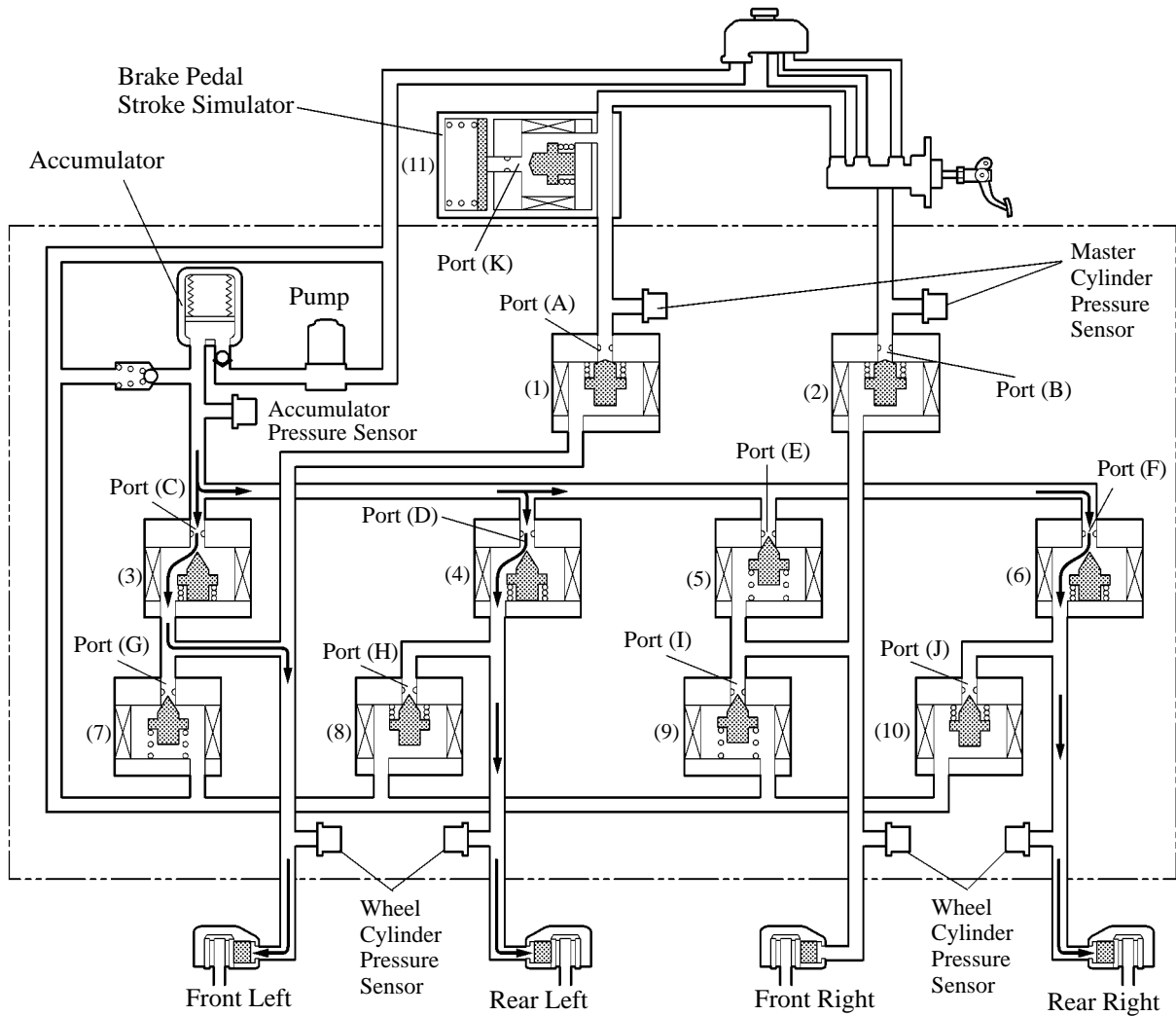

**Increase Mode**

Item		VSC not Activated	VSC Activated			
			Increase Mode	Holding Mode	Reduction Mode	
(1), (2)	Master Cylinder Cut Solenoid Valve	ON (Close)	ON (Close)	ON (Close)	ON (Close)	
	Port: (A), (B)					
Front Brake	(3)	Pressure Appliance Solenoid Valve	OFF (Close)	ON (Half-Open*)	OFF (Close)	OFF (Close)
		Port: (C)				
	(5)	Pressure Appliance Solenoid Valve	OFF (Close)	OFF (Close)	OFF (Close)	OFF (Close)
		Port: (E)				
	(7)	Pressure Reduction Solenoid Valve	OFF (Close)	OFF (Close)	OFF (Close)	ON (Half-Open*)
		Port: (G)				
	(9)	Pressure Reduction Solenoid Valve	OFF (Close)	OFF (Close)	OFF (Close)	OFF (Close)
		Port: (I)				
	Wheel Cylinder Pressure	Right	—	—	—	—
		Left	—	Increase	Hold	Reduction
Rear Brake	(4)	Pressure Appliance Solenoid Valve	OFF (Close)	OFF (Close)	OFF (Close)	OFF (Close)
		Port: (D)				
	(6)	Pressure Appliance Solenoid Valve	OFF (Close)	ON (Half-Open*)	OFF (Close)	OFF (Close)
		Port: (F)				
	(8)	Pressure Reduction Solenoid Valve	OFF (Open)	ON (Close)	OFF (Open)	ON (Half-Open*)
		Port: (H)				
	(10)	Pressure Reduction Solenoid Valve	OFF (Open)	ON (Close)	ON (Close)	ON (Half-Open*)
		Port: (J)				
	Wheel Cylinder Pressure	Right	—	Increase	Hold	Reduction
		Left				
(11)	Stroke Simulator Cut Solenoid Valve	ON (Open)	ON (Open)	ON (Open)	ON (Open)	
	Port: (K)					

\*: The solenoid valve constantly regulates the amount of opening of the port in accordance with the use conditions in order to control the fluid pressure.

**c. Rear Wheel Skid Restraint Control (Turning to the Right)**

- In rear wheel skid tendency, this management function applies the brake to the front wheel of the outer circle of the turn. In some cases, the skid control ECU applies the brake to the rear wheels, as necessary. As an example, the diagram below shows the hydraulic circuit in the pressure increase mode, as it restrains the rear wheel skid condition while the vehicle makes a right turn.
- As in front wheel skid restraint control, the pressure appliance valve and the pressure reduction valve are turned ON/OFF according to the ABS operating pattern.

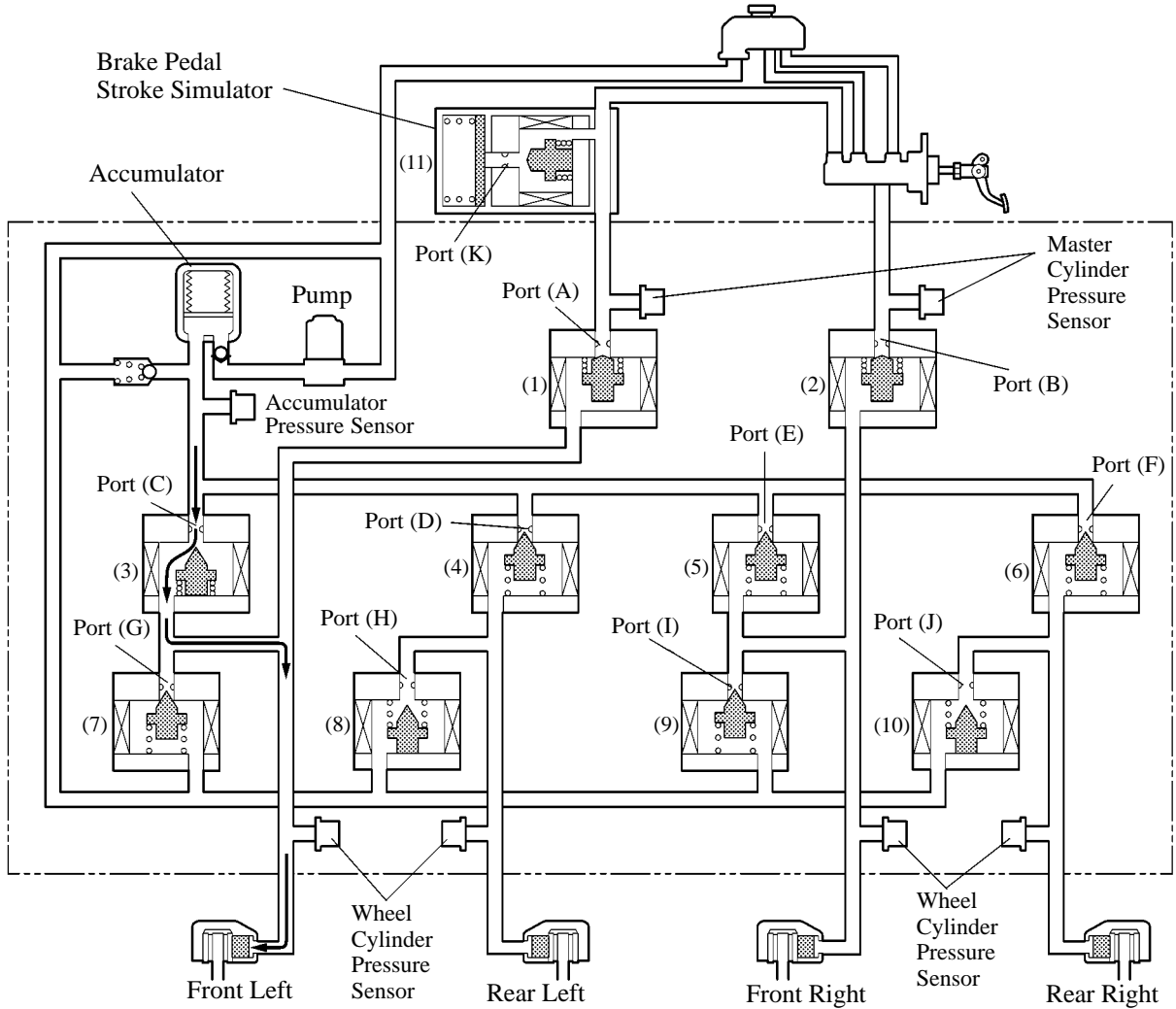

**Increase Mode**

Item		VSC not Activated	VSC Activated			
			Increase Mode	Holding Mode	Reduction Mode	
(1), (2)	Master Cylinder Cut Solenoid Valve	ON (Close)	ON (Close)	ON (Close)	ON (Close)	
	Port: (A), (B)					
Front Brake	(3)	Pressure Appliance Solenoid Valve	OFF (Close)	ON (Half-Open*1)	OFF (Close)	OFF (Close)
		Port: (C)				
	(5)	Pressure Appliance Solenoid Valve	OFF (Close)	OFF (Close)	OFF (Close)	OFF (Close)
		Port: (E)				
	(7)	Pressure Reduction Solenoid Valve	OFF (Close)	OFF (Close)	OFF (Close)	ON (Half-Open*1)
		Port: (G)				
	(9)	Pressure Reduction Solenoid Valve	OFF (Close)	OFF (Close)	OFF (Close)	OFF (Close)
		Port: (I)				
	Wheel Cylinder Pressure	Right	—	—	—	—
		Left	—	Increase	Hold	Reduction
Rear Brake	(4)	Pressure Appliance Solenoid Valve	OFF (Close)	OFF (Close) [ON (Half-Open*1)]*2	OFF (Close)	OFF (Close)
		Port: (D)				
	(6)	Pressure Appliance Solenoid Valve	OFF (Close)	OFF (Close) [ON (Half-Open*1)]*2	OFF (Close)	OFF (Close)
		Port: (F)				
	(8)	Pressure Reduction Solenoid Valve	OFF (Open)	OFF (Open)	ON (Close)	ON (Close) [ON (Half-Open*1)]*2
		Port: (H)				
	(10)	Pressure Reduction Solenoid Valve	OFF (Open)	OFF (Open)	ON (Close)	ON (Close) [ON (Half-Open*1)]*2
		Port: (J)				
	Wheel Cylinder Pressure	Right	—	—	—	—
		Left	—	—	—	—
(11)	Stroke Simulator Cut Solenoid Valve	ON (Open)	ON (Open)	ON (Open)	ON (Open)	
	Port: (K)					

\*1: The solenoid valve constantly regulates the amount of opening of the port in accordance with the use conditions in order to control the fluid pressure.

\*2: In some cases, the skid control ECU applies the brake of the rear wheels, as necessary.

## Skid Control ECU

### 1) Motive Force Control

During a brake control operation (TRAC or VSC function), the skid control ECU outputs a motive force control request signal to the THS ECU. Upon receiving this signal, the THS ECU effects motive force control.

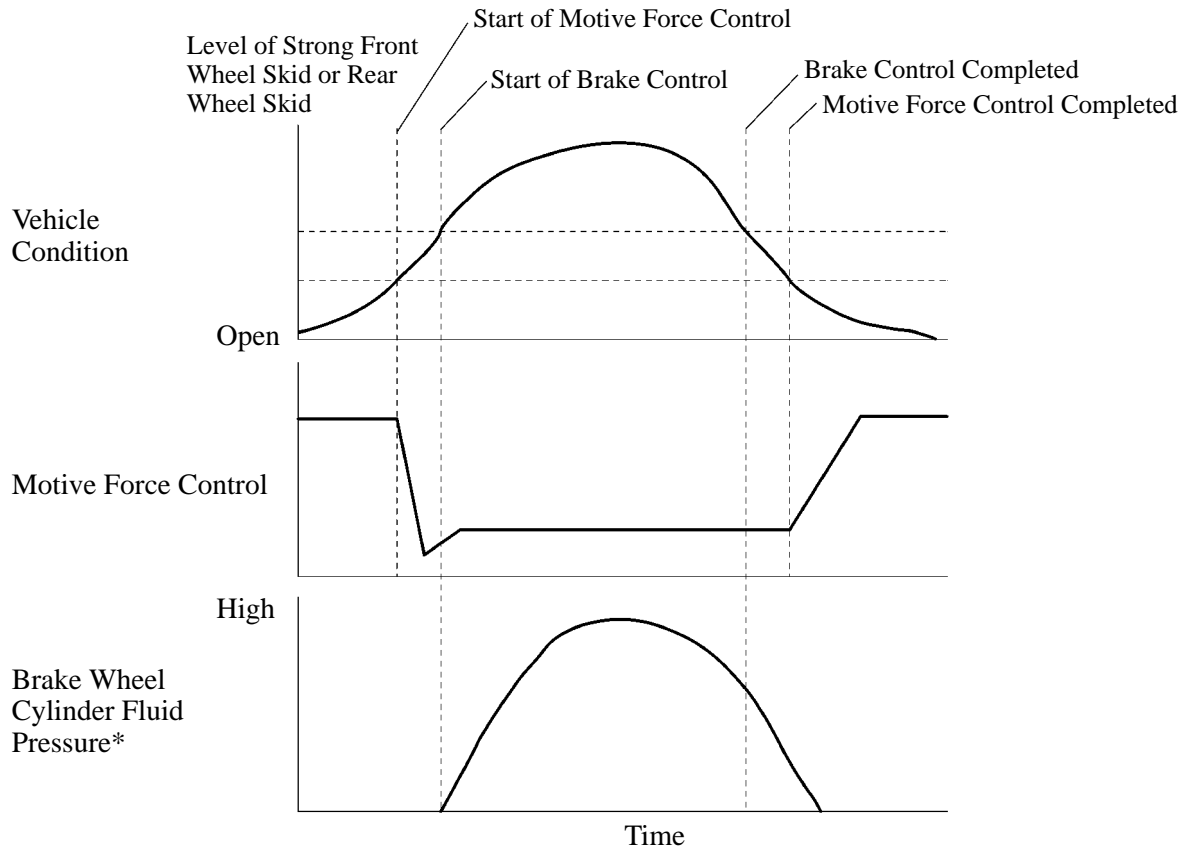

151CH31

\*: The wheel cylinder that activates varies depending on the condition of the vehicle.

## 2) Diagnosis

- If a failure occurs in one of the sensors or actuators in the brake system, the skid control ECU informs the driver of the failure in the brake system by illuminating the ECB\* warning light, brake system warning light, or ABS warning light in the combination meter, or displaying a VSC warning message/“CHECK VSC SYSTEM” (on the multi-information display).
- At the same time, a DTC (Diagnostic Trouble Code) is stored in memory. The DTC can be accessed by connecting the SST (09843-18040) between the Tc and CG terminals of the DLC3 connector and checking the blinking of the ABS warning light, ECB\* warning light, or the “DIAG VSC” that appears on the multi-information display. Another way to access the DTC is to connect a hand-held tester and read the code that appears on the tester.
- This system has a sensor signal check (test mode) function. This function is activated by connecting the SST (09843-18040) between the Ts and CG terminals of the DLC3 or by connecting a hand-held tester.
- If the CAN has communication error ECU or sensors, multiple DTCs are output simultaneously to indicate the malfunction location.
- Three-digit information codes have been provided in the conventional DTC as subset of a primary five-digit code. This enables the troubleshooting procedure to further narrow down a trouble area to identify a problem.
- For details on the DTC that are stored in skid control ECU memory and the DTC that are output through the sensor signal check function, see the 2007 Camry Hybrid Vehicle Repair Manual (Pub. No. RM02H0U).

\*: ECB (Electronically Controlled Brake System)

### ► Display example of the multi-information display ◀



**Normal system code is displayed**

025CH50P



**DTC is displayed**

025CH56P

#### Service Tip

The skid control ECU uses the CAN protocol for diagnostic communication. Therefore, a hand-held tester and a dedicated adapter [CAN VIM (Vehicle Interface Module)] are required for accessing diagnostic data. For details, see the 2007 Camry Hybrid Vehicle Repair Manual (Pub. No. RM02H0U).

## 3) Fail-Safe

- If a failure occurs in the skid control ECU, sensors, and/or brake actuators, the system continues effecting brake control by excluding the failed area and using only the areas that are operating normally.
- If the regenerative brake becomes unusable due to a failure in communication with the THS ECU, the skid control ECU uses the hydraulic brake force to control the entire braking force.